

SUPERO[®]

SC808 Chassis Series

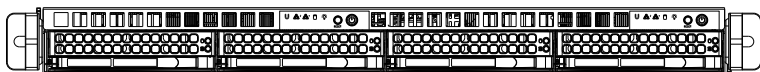

SC808T-1200W	
SC808T-980V	SC808T-980B
SC808T-780B	SC808LT-780B

USER'S MANUAL

1.0b

The information in this User's Manual has been carefully reviewed and is believed to be accurate. The vendor assumes no responsibility for any inaccuracies that may be contained in this document, makes no commitment to update or to keep current the information in this manual, or to notify any person or organization of the updates. **Please Note: For the most up-to-date version of this manual, please see our web site at www.supermicro.com.**

Super Micro Computer, Inc. ("Supermicro") reserves the right to make changes to the product described in this manual at any time and without notice. This product, including software, if any, and documentation may not, in whole or in part, be copied, photocopied, reproduced, translated or reduced to any medium or machine without prior written consent.

IN NO EVENT WILL SUPERMICRO BE LIABLE FOR DIRECT, INDIRECT, SPECIAL, INCIDENTAL, SPECULATIVE OR CONSEQUENTIAL DAMAGES ARISING FROM THE USE OR INABILITY TO USE THIS PRODUCT OR DOCUMENTATION, EVEN IF ADVISED OF THE POSSIBILITY OF SUCH DAMAGES. IN PARTICULAR, SUPERMICRO SHALL NOT HAVE LIABILITY FOR ANY HARDWARE, SOFTWARE, OR DATA STORED OR USED WITH THE PRODUCT, INCLUDING THE COSTS OF REPAIRING, REPLACING, INTEGRATING, INSTALLING OR RECOVERING SUCH HARDWARE, SOFTWARE, OR DATA.

Any disputes arising between manufacturer and customer shall be governed by the laws of Santa Clara County in the State of California, USA. The State of California, County of Santa Clara shall be the exclusive venue for the resolution of any such disputes. Super Micro's total liability for all claims will not exceed the price paid for the hardware product.

California Best Management Practices Regulations for Perchlorate Materials: This Perchlorate warning applies only to products containing CR (Manganese Dioxide) Lithium coin cells. "Perchlorate Material-special handling may apply. See www.dtsc.ca.gov/hazardouswaste/perchlorate"

WARNING: Handling of lead solder materials used in this product may expose you to lead, a chemical known to the State of California to cause birth defects and other reproductive harm.

Manual Revision 1.0b
Release Date: December 16, 2009

Unless you request and receive written permission from Super Micro Computer, Inc., you may not copy any part of this document.

Information in this document is subject to change without notice. Other products and companies referred to herein are trademarks or registered trademarks of their respective companies or mark holders.

Copyright © 2009 by Super Micro Computer, Inc.
All rights reserved.

Printed in the United States of America

Preface

About This Manual

This manual is written for professional system integrators and PC technicians. It provides information for the installation and use of the SC808 1U chassis. Installation and maintenance should be performed by experienced technicians only.

Supermicro's SC808 1U chassis features a unique and highly-optimized design for 1U Twin™ servers. The layout and chassis design provides 2 nodes in 1U and up to 84 nodes in a 42U standard rack, which significantly reduces IT space costs. With double the connectivity, each node also supports dual 3.5" hot-swap drive bays. The SC808 chassis reduces cost by providing higher power efficiency and provides simplified cabling, better air flow, and easier maintenance. The Gold Level high-efficiency 1200W power supply makes this high-density server chassis even more powerful! Bulk package and quick release slide rails are also available for HPC and datacenter use.

This document lists compatible parts available when this document was published. Always refer to the our Web site for updates on supported parts and configurations.

Manual Organization

Chapter 1: Introduction

The first chapter provides a checklist of the main components included with this chassis, and describes the main features of the SC808 chassis. This chapter also includes contact information.

Chapter 2: System Safety

This chapter lists warnings, precautions, and system safety. You should thoroughly familiarize yourself with this chapter for a general overview of safety precautions that should be followed before installing and servicing this chassis.

Chapter 3: Chassis Components

Refer here for details on this chassis model including the fans, bays, airflow shields, and other components.

Chapter 4: System Interface

Refer to this chapter for details on the system interface, which includes the functions and information provided by the control panel on the chassis as well as other LEDs located throughout the system.

Chapter 5: Chassis Setup and Maintenance

Follow the procedures given in this chapter when installing or removing components, or reconfiguring your chassis.

Chapter 6: Rack Installation

Refer to this chapter for detailed information on chassis rack installation. You should follow the procedures given in this chapter when installing, removing or reconfiguring your chassis into a rack environment.

Compatible Backplanes

This section lists compatible cables, power supply specifications, and compatible backplanes. Not all compatible backplanes are listed. Refer to our Web site for the latest compatible backplane information.

Appendix A: Chassis Cables

Appendix B: Power Supply Specifications

Appendix C: SAS-808 Backplane Specifications

Table of Contents

Preface

About This Manual	iii
Manual Organization	iv

Chapter 1 Introduction

1-1 Overview	1-1
1-2 Shipping List.....	1-1
Part Numbers	1-1
1-3 Contacting Supermicro.....	1-2
1-4 Returning Merchandise for Service.....	1-3

Chapter 2 System Safety

2-1 Overview	2-1
2-2 Warnings and Precautions	2-1
2-3 Preparing for Setup.....	2-1
2-4 Electrical Safety Precautions	2-1
2-5 General Safety Precautions	2-2
2-6 System Safety	2-3

Chapter 3 Chassis Components

3-1 Overview	3-1
3-2 Components.....	3-1
3-3 Where to get Replacement Components.....	3-2

Chapter 4 System Interface

4-1 Overview	4-1
4-2 Control Panel Buttons	4-2
4-3 Control Panel LEDs	4-2
4-4 Drive Carrier LEDs	4-3

Chapter 5 Chassis Setup and Maintenance

5-1 Overview	5-1
5-2 Removing the Chassis Cover	5-2
5-3 Installing and Removing Hard Drives	5-3
5-4 Installing the Motherboard	5-6
Permanent and Optional Standoffs.....	5-6
Expansion Slot Setup.....	5-8
5-5 Installing the Air Shrouds	5-10
Air Shrouds	5-10
5-6 Checking the Air Flow	5-11
Installation Complete.....	5-11

5-7	System Fans	5-12
5-8	Power Supply	5-14
	Power Supply Replacement.....	5-14

Chapter 6 Rack Installation

6-1	Overview	6-1
6-2	Unpacking the System	6-1
6-3	Preparing for Setup	6-1
	Choosing a Setup Location.....	6-1
	Rack Precautions	6-2
	General Server Precautions.....	6-2
	Rack Mounting Considerations	6-3
	Ambient Operating Temperature	6-3
	Reduced Airflow	6-3
	Mechanical Loading	6-3
	Circuit Overloading.....	6-3
	Reliable Ground	6-3
6-4	Rack Mounting Instructions.....	6-4
	Identifying the Sections of the Rack Rails.....	6-4
	Installing the Inner Rail Extension	6-5

Appendix A Cables, Screws, and other Accessories

Appendix B SC808 Power Supply Specifications

Appendix C SAS-808 Backplane Specifications

Notes

Chapter 1

Introduction

1-1 Overview

Supermicro's SC808 1U chassis features a unique and highly-optimized design. The chassis is equipped with a high-efficiency power supply. High-performance fans provide ample optimized cooling for FB-DIMM memory modules and 4 hot-swappable drive bays offer maximum storage capacity in a 1U form factor.

1-2 Shipping List

Part Numbers

Please visit the following link for the latest shipping lists and part numbers for your particular chassis model <http://www.supermicro.com/products/chassis/1U/?chs=808>

SC808 Chassis				
Model	CPU	HDD	I/O Slots	Power Supply
SC808T-980V	Single/Dual CPU	4x SATA	2x LP	980W
SC808T-980B	Single/Dual CPU	4x SATA	2x LP	980W
SC808T-780B	Single/Dual CPU	4x SATA	2x LP	780W
SC808TQ-980B	Single/Dual CPU	4x SATA	2x LP	780W

1-3 Contacting Supermicro

Headquarters

Address: Super Micro Computer, Inc.
980 Rock Ave.
San Jose, CA 95131 U.S.A.

Tel: +1 (408) 503-8000
Fax: +1 (408) 503-8008
Email: marketing@supermicro.com (General Information)
support@supermicro.com (Technical Support)

Web Site: www.supermicro.com

Europe

Address: Super Micro Computer B.V.
Het Sterrenbeeld 28, 5215 ML
's-Hertogenbosch, The Netherlands

Tel: +31 (0) 73-6400390
Fax: +31 (0) 73-6416525
Email: sales@supermicro.nl (General Information)
support@supermicro.nl (Technical Support)
rma@supermicro.nl (Customer Support)

Asia-Pacific

Address: Super Micro Computer, Inc.
4F, No. 232-1, Liancheng Rd.
Chung-Ho 235, Taipei County
Taiwan, R.O.C.

Tel: +886-(2) 8226-3990
Fax: +886-(2) 8226-3991
Web Site: www.supermicro.com.tw
Technical Support:
Email: support@supermicro.com.tw
Tel: 886-2-8226-1900

1-4 Returning Merchandise for Service

A receipt or copy of your invoice marked with the date of purchase is required before any warranty service will be rendered. You can obtain service by calling your vendor for a Returned Merchandise Authorization (RMA) number. When returning to the manufacturer, the RMA number should be prominently displayed on the outside of the shipping carton, and mailed prepaid or hand-carried. Shipping and handling charges will be applied for all orders that must be mailed when service is complete.

For faster service, RMA authorizations may be requested online (<http://www.supermicro.com/support/rma/>).

Whenever possible, repack the chassis in the original Supermicro carton, using the original packaging material. If these are no longer available, be sure to pack the chassis securely, using packaging material to surround the chassis so that it does not shift within the carton and become damaged during shipping.

This warranty only covers normal consumer use and does not cover damages incurred in shipping or from failure due to the alteration, misuse, abuse or improper maintenance of products.

During the warranty period, contact your distributor first for any product problems.

Notes

Chapter 2

System Safety

2-1 Overview

This chapter provides a quick setup checklist to get your chassis up and running. Following the steps in order given should enable you to have your chassis set up and operational within a minimal amount of time. This quick setup assumes that you are an experienced technician, familiar with common concepts and terminology.

2-2 Warnings and Precautions

You should inspect the box the chassis was shipped in and note if it was damaged in any way. If the chassis itself shows damage, file a damage claim with carrier who delivered your system.

Decide on a suitable location for the rack unit that will hold that chassis. It should be situated in a clean, dust-free area that is well ventilated. Avoid areas where heat, electrical noise and electromagnetic fields are generated.

You will also need it placed near at least one grounded power outlet. When configured, the SC808 chassis includes one power supply.

2-3 Preparing for Setup

The SC808 Chassis includes a set of rail assemblies, including mounting brackets and mounting screws you will need to install the systems into the rack. Please read this manual in its entirety before you begin the installation procedure.

2-4 Electrical Safety Precautions

Basic electrical safety precautions should be followed to protect yourself from harm and the SC808 from damage:

- Be aware of the locations of the power on/off switch on the chassis as well as the room's emergency power-off switch, disconnection switch or electrical outlet. If an electrical accident occurs, you can then quickly remove power from the system.
- Do not work alone when working with high voltage components.

- Power should always be disconnected from the system when removing or installing main system components, such as the serverboard, memory modules and the DVD-ROM and floppy drives (not necessary for hot swappable drives). When disconnecting power, you should first power down the system with the operating system and then unplug the power cords from all the power supply modules in the system.
- When working around exposed electrical circuits, another person who is familiar with the power-off controls should be nearby to switch off the power, if necessary.
- Use only one hand when working with powered-on electrical equipment. This is to avoid making a complete circuit, which will cause electrical shock. Use extreme caution when using metal tools, which can easily damage any electrical components or circuit boards they come into contact with.
- Do not use mats designed to decrease electrostatic discharge as protection from electrical shock. Instead, use rubber mats that have been specifically designed as electrical insulators.
- The power supply power cord must include a grounding plug and must be plugged into grounded electrical outlets.
- Serverboard battery: CAUTION - There is a danger of explosion if the onboard battery is installed upside down, which will reverse its polarities This battery must be replaced only with the same or an equivalent type recommended by the manufacturer. Dispose of used batteries according to the manufacturer's instructions.
- Please handle used batteries carefully. Do not damage the battery in any way; a damaged battery may release hazardous materials into the environment. Do not discard a used battery in the garbage or a public landfill. Please comply with the regulations set up by your local hazardous waste management agency to dispose of your used battery properly.
- DVD-ROM laser: CAUTION - this server may have come equipped with a DVD-ROM drive. To prevent direct exposure to the laser beam and hazardous radiation exposure, do not open the enclosure or use the unit in any unconventional way.

2-5 General Safety Precautions

- Keep the area around the chassis clean and free of clutter.
- Place the chassis top cover and any system components that have been removed away from the system or on a table so that they won't accidentally be stepped on.
- While working on the system, do not wear loose clothing such as neckties and unbuttoned shirt sleeves, which can come into contact with electrical circuits or be pulled into a cooling fan.
- Remove any jewelry or metal objects from your body, which are excellent metal conductors that can create short circuits and harm you if they come into contact with printed circuit boards or areas where power is present.
- After accessing the inside of the system, close the system back up and secure it to the rack unit with the retention screws after ensuring that all connections have been made.

2-6 System Safety

Electrostatic discharge (ESD) is generated by two objects with different electrical charges coming into contact with each other. An electrical discharge is created to neutralize this difference, which can damage electronic components and printed circuit boards. The following measures are generally sufficient to neutralize this difference before contact is made to protect your equipment from ESD:

- Do not use mats designed to decrease electrostatic discharge as protection from electrical shock. Instead, use rubber mats that have been specifically designed as electrical insulators.
- Use a grounded wrist strap designed to prevent static discharge.
- Keep all components and printed circuit boards (PCBs) in their antistatic bags until ready for use.
- Touch a grounded metal object before removing any board from its antistatic bag.
- Do not let components or PCBs come into contact with your clothing, which may retain a charge even if you are wearing a wrist strap.

- Handle a board by its edges only; do not touch its components, peripheral chips, memory modules or contacts.
- When handling chips or modules, avoid touching their pins.
- Put the serverboard and peripherals back into their antistatic bags when not in use.
- For grounding purposes, make sure your computer chassis provides excellent conductivity between the power supply, the case, the mounting fasteners and the serverboard.

Chapter 3

Chassis Components

3-1 Overview

This chapter describes the most common components included with your chassis. Some components listed may not be included or compatible with your particular chassis model. For more information, see the installation instructions detailed later in this manual.

3-2 Components

Chassis

The SC808 chassis includes four hard drive bays. Hard drives must be purchased separately. For the latest shipping lists, visit our Web site at: <http://www.supermicro.com>.

Backplane

Each SC808 chassis comes with a 1U backplane. For more information regarding compatible backplanes, view the appendices found at the end of this manual. In addition, visit our Web site for the latest information: <http://www.supermicro.com>.

Fans

The SC808 chassis accepts six system fans . System fans for SC808 chassis are powered from the serverboard. These fans are 1U high and are powered by 3-pin connectors.

Mounting Rails

The SC808 can be placed in a rack for secure storage and use. To set up your rack, follow the step-by-step instructions included in this manual.

Power Supply

Each SC808 chassis model includes a high-efficiency power supply rated at 780, 980 or 1200 Watts. In the unlikely event your power supply fails, replacement is simple and can be accomplished without tools.

Air Shroud

The SC808 chassis includes two mylar air shrouds that funnel air directly to where it is needed. Always use the air shroud included with your chassis.

3-3 Where to get Replacement Components

Though not frequently, you may need replacement parts for your system. To ensure the highest level of professional service and technical support, we strongly recommend purchasing exclusively from our Supermicro Authorized Distributors / System Integrators / Resellers. A list of Supermicro Authorized Distributors / System Integrators / Reseller can be found at: <http://www.supermicro.com>. Click the Where to Buy link.

Chapter 4

System Interface

4-1 Overview

There are several LEDs on the control panel and drive carriers to keep you constantly informed of the overall status of the system. SC808 models include two front panels that control two semi-independent system.

This chapter explains the meanings of all LED indicators and the appropriate response you may need to take.

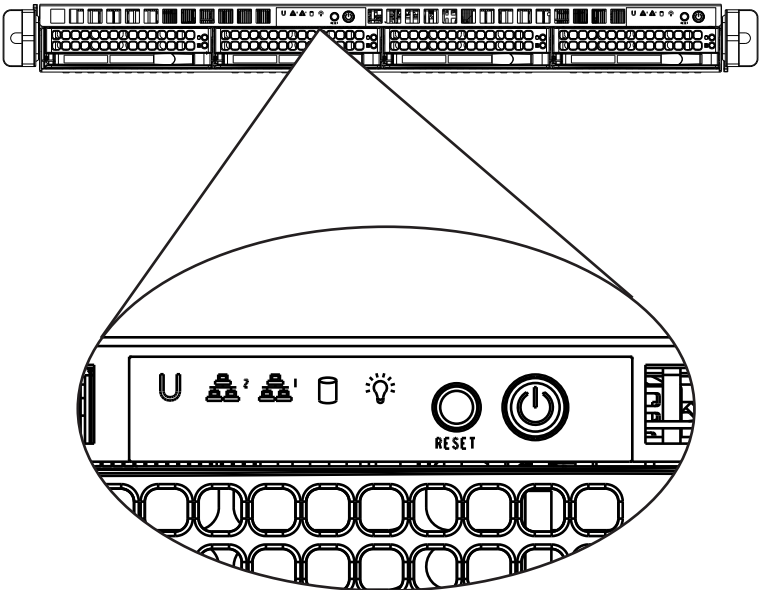

4-2 Control Panel Buttons

There are two push-buttons located on the front of the chassis. These are (in order from left to right) a reset button and a power on/off button.

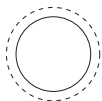

- **Reset:** The reset button is used to reboot the system.



- **Power:** The main power switch is used to apply or remove power from the power supply to the server system. Turning off system power with this button removes the main power but keeps standby power supplied to the system. Therefore, you must unplug system before servicing.

4-3 Control Panel LEDs

The control panel located on the front of the SC808 chassis has five LEDs. These LEDs provide you with critical information related to different parts of the system. This section explains what each LED indicates when illuminated and any corrective action you may need to take.



- **Universal Information LED:** The Universal Information LED is used to indicate fan failure, power failure, overheat condition, or to identify the unit within a large rack installation. The feature requires a motherboard that supports the Universal Information LED.

When this LED blinks red quickly, it indicates a fan failure and when blinking red slowly a power failure. This LED will be blue when used for UID (Unit Identifier). When on continuously red, it indicates an overheat condition, which may be caused by cables obstructing the airflow in the system or the ambient room temperature being too warm. See the table below for descriptions of the LED states



- NIC2: Indicates network activity on GLAN2 when flashing.



- NIC1: Indicates network activity on GLAN1 when flashing.



- HDD: Indicates IDE channel activity. SAS/SATA drive, and/or DVD-ROM drive activity when flashing.



- Power: Indicates power is being supplied to the system's power supply units. This LED should normally be illuminated when the system is operating.

4-4 Drive Carrier LEDs

Your chassis uses SAS/SATA drives.

SAS/SATA Drives

Each SAS/SATA drive carrier has two LEDs.

- Green: Each Serial ATA drive carrier has a green LED. When illuminated, this green LED (on the front of the SATA drive carrier) indicates drive activity. A con-

nection to the SATA backplane enables this LED to blink on and off when that particular drive is being accessed.

- Red: The red LED to indicate an SAS/SATA drive failure. If one of the SAS/SATA drives fail, you should be notified by your system management software.

SCSI Drives

This chassis does not support SCSI drives at this time.

Chapter 5

Chassis Setup and Maintenance

5-1 Overview

This chapter covers the steps required to install components and perform maintenance on the chassis. The only tool you will need to install components and perform maintenance is a Phillips screwdriver.

- Overview
- Removing the Chassis Cover
- Installing and Removing Hard Drives
- Installing the Motherboard
- Expansion Card Setup
- Installing the Air Shrouds
- Checking the Chassis the Air Flow
- System Fans
- Power Supply



Review the warnings and precautions listed in the manual before setting up or servicing this chassis. These include information in Chapter 2: System Safety and the warning/precautions listed in the setup instructions.

5-2 Removing the Chassis Cover

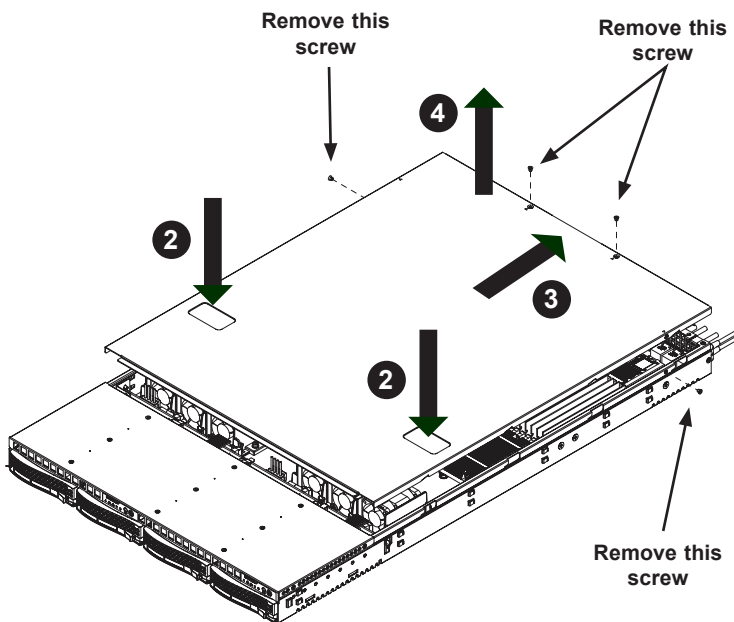

Figure 5-1: Removing the Chassis Cover

Removing the Chassis Cover

1. Disconnect the chassis from any power source and remove all four screws.
2. Gently push down on the chassis cover in the areas indicated in the illustration.
3. Push the cover toward the rear of the chassis
4. Lift the cover upwards and off the chassis.



Warning: Except for short periods of time, do NOT operate the server without the cover in place. The chassis cover must be in place to allow proper airflow and prevent overheating.

5-3 Installing and Removing Hard Drives

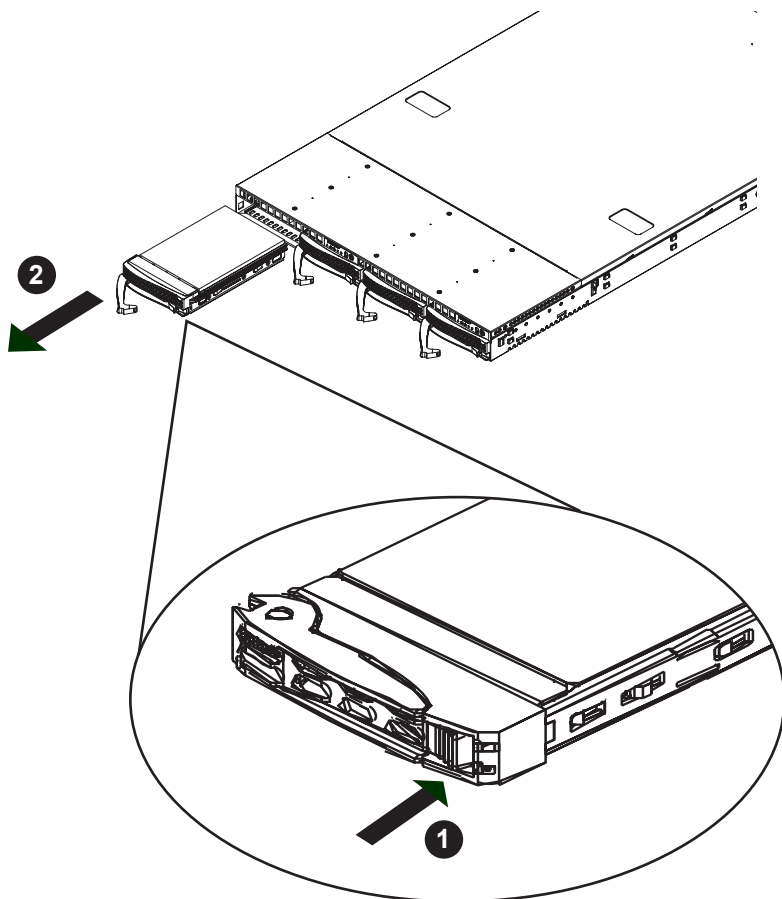

Figure 5-2: Removing Hard Drive

Removing Hard Drive Carriers from the Chassis

1. Press the release button on the drive carrier. This extends the drive handle.
2. Use the handle to pull the drive out of the chassis.

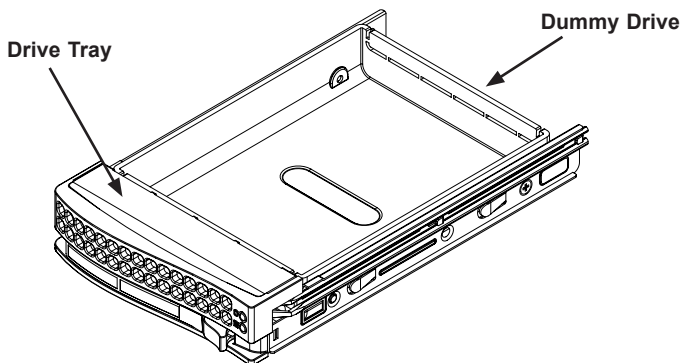

Figure 5-3: Chassis Drive Carrier

The drives are mounted in drive carriers to simplify their installation and removal from the chassis. These carriers also help promote proper airflow in the drive bays.



Warning: Except for short periods of time (swapping hard drives), do not operate the server with the carriers absent.

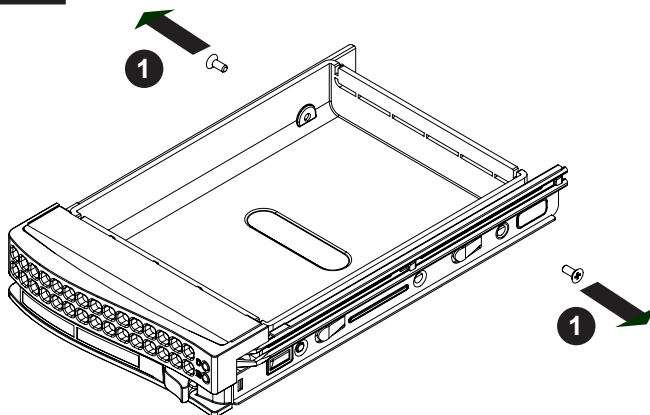

Figure 5-4: Removing Dummy Drive from Carrier

Installing a Drive into the Hard Drive Carrier

1. Remove the two screws securing the dummy drive to the drive carrier.
2. Lift the dummy drive up and out of the carrier.

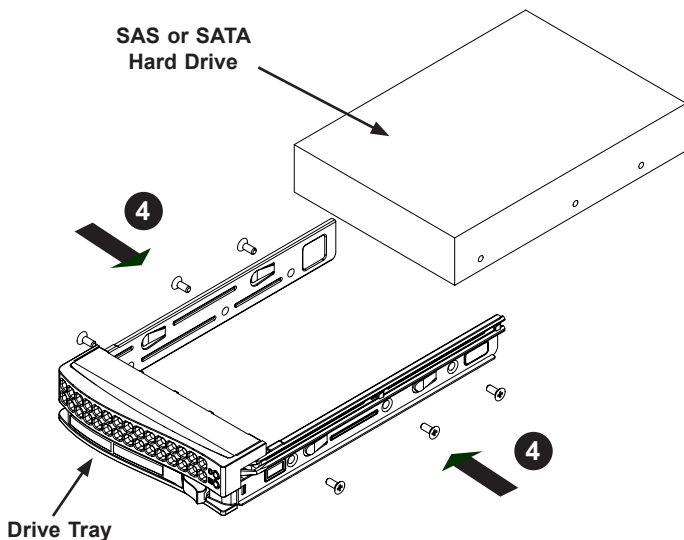

Figure 5-5: Removing Hard Drive

3. Install a new drive into the carrier with the printed circuit board side facing downward so that the mounting holes align with those in the carrier.
4. Secure the hard drive by tightening all six screws.
5. Use the open handle to slide the drive carrier into the chassis.
6. Close the drive carrier handle.



Warning! Enterprise level hard disk drives are recommended for use in Supermicro chassis and servers. For information on recommended HDDs, visit the Supermicro Web site at <http://www.supermicro.com/products/nfo/files/storage/SAS-1-CompList-110909.pdf>

5-4 Installing the Motherboard

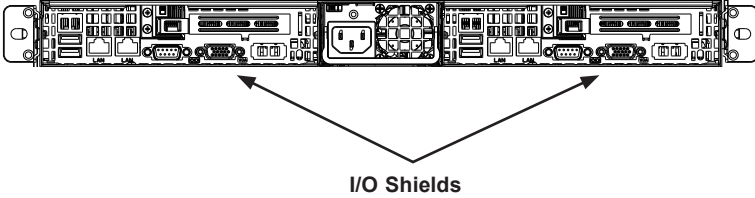

Figure 5-6: I/O Shield Placement

I/O Shield

The I/O shield holds the motherboard ports in place. The I/O shield does not require installation, however, the motherboard must match up with the I/O shield.

Permanent and Optional Standoffs

Standoffs prevent short circuits by securing space between the motherboard and the chassis surface. The SC808 chassis includes permanent standoffs in locations used by the motherboards. These standoffs accept the rounded Phillips head screws included in the SC808 accessories packaging.

Some motherboards require additional screws for heatsinks, general components and for stability. Optional standoffs are used for these motherboards.

To use an optional standoff, you must place a hexagonal screw through the bottom the chassis and secure the screw with the hexagonal nut (rounded side up).

Depending upon the configuration of the motherboard being used, it is also possible that some of the optional standoffs which are pre-installed in the chassis, may need to be removed.

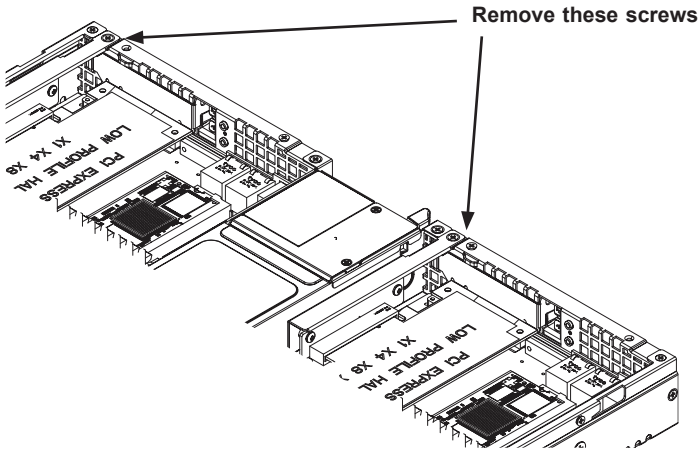

Figure 5-7: Expansion Card Bracket

Installing the Motherboard

1. Review the documentation that came with your motherboard. Become familiar with component placement, requirements, precautions, and cable connections.
2. Disconnect the chassis from any power source and open the chassis cover.
3. Remove the expansion card brackets. To do this:
 - A. Remove screw securing the expansion card bracket to the chassis.
 - B. Lift the bracket out of the chassis.
 - C. Repeat this process for the second riser card.
4. Lay the first motherboard in the chassis aligning the standoffs
5. Secure the motherboard to the chassis using the rounded, Phillips head screws. Each motherboard requires five screws. Do not exceed eight pounds of torque when tightening down the motherboard.
6. Repeat steps 3 - 5 for the second side of the chassis.
7. Secure the CPU(s), heatsinks, and other components to the motherboard as described in the motherboard documentation.

8. Connect the cables between the motherboard, backplane, chassis, front panel, and power supply, as needed. Also, fans may be temporarily removed to allow access to the backplane ports.
9. Replace the expansion card bracket and secure the bracket with a screw.

Expansion Slot Setup

SC808 chassis includes I/O slots for expansion cards. Each side supports one low profile, half-length expansion card for a total of two per system.

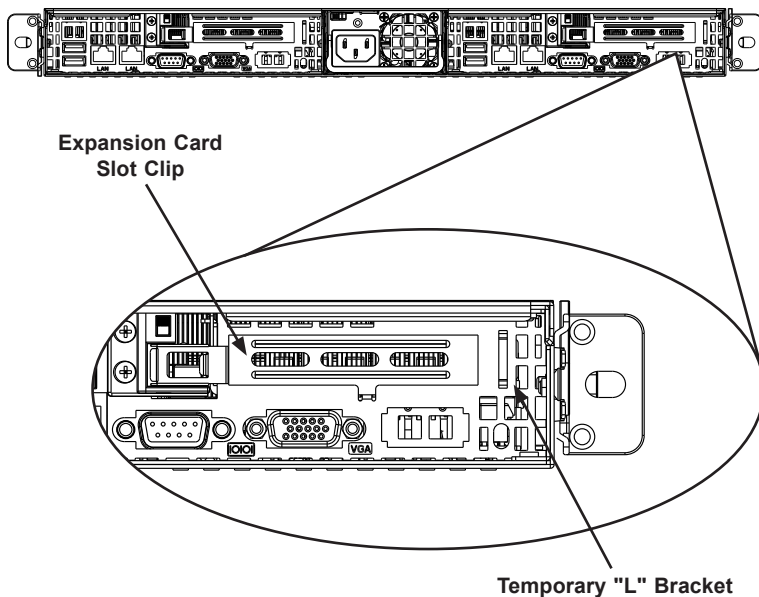

Figure 5-8: I/O Shield Placement

Installing Expansion Cards

1. Disconnect the chassis from any power source, lay the chassis on a flat surface, and open the chassis cover.
2. Pull open the expansion card slot clip in the rear of the chassis.
3. Slide the temporary expansion card "L" bracket toward the slot clip and remove the temporary bracket from the chassis.

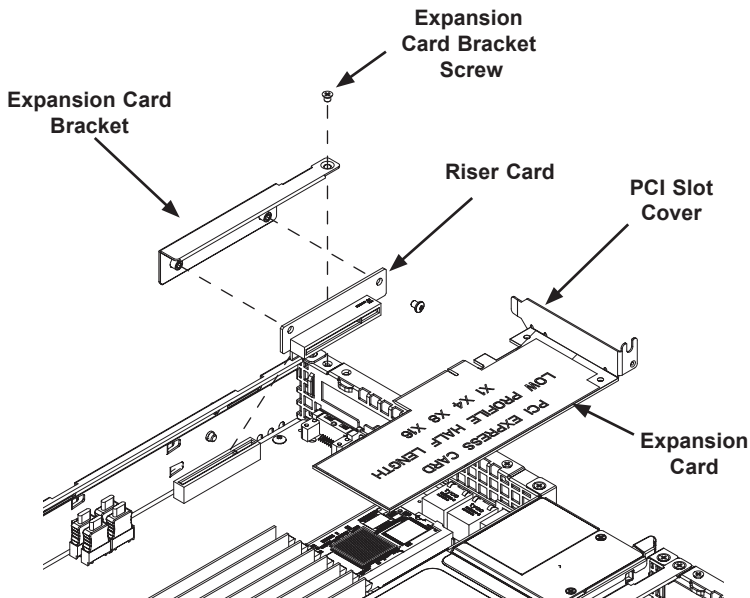

Figure 5-9: I/O Shield Placement

4. Connect the expansion card to the riser card and slide the expansion card "L" bracket in to the rear expansion card slot.
5. Close the expansion card slot clip.
6. Close the chassis cover and reconnect the chassis to the power source.

Note: Under normal circumstances, the riser card and expansion card bracket are not separated.

5-5 Installing the Air Shrouds

Air Shrouds

Air shrouds concentrate airflow to maximize fan efficiency. The SC808 chassis air shroud does not require screws to set up. The SC808 chassis requires two identical air shrouds.

Installing an Air Shroud

1. Confirm that all six fans are in place and working properly
2. Place the first air shroud into the chassis. The air shroud sits behind the system fans. Each air shroud covers three fans.
3. Install the second air shroud in the same manner as the first.

5-6 Checking the Air Flow

Checking Air Flow

1. Make sure there are no objects obstructing airflow in and out of the server. In addition, if you are using a front bezel, make sure the bezel's filter is replaced periodically.
2. Do not operate the server without drives or drive carriers in the drive bays. Use only recommended server parts.
3. Make sure no wires or foreign objects obstruct air flow through the chassis. Pull all excess cabling out of the airflow path or use shorter cables.
4. The control panel LEDs inform you of system status. See “Chapter 3: System Interface” for details on the LEDs and the control panel buttons.

Installation Complete

In most cases, the chassis power supply and fans are pre-installed. If you need to install them, continue to the Power Supply or Systems Fans sections of this chapter. If the chassis will be installed into a rack, continue to the Rack Installation chapter for rack installation instructions.

5-7 System Fans

Six fans provide cooling for the chassis. These fans circulate air through the chassis as a means of lowering the chassis internal temperature. The SC808 system fans are hot-swappable. There is no need to power-down the system when switching fans.

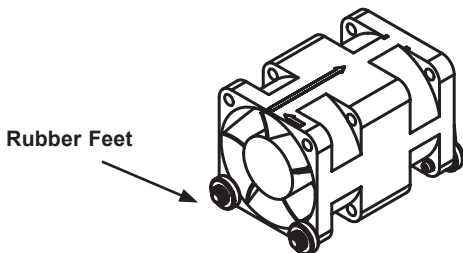

Figure 5-10: System Fan

Changing a System Fan

1. If necessary, open the chassis while the power is running to determine which fan has failed. (Never run the server for an extended period of time with the chassis open.)
2. Remove the failed fan's power cord from the serverboard.
3. Lift the fan from the chassis.
4. Place the new fan into the vacant space in the housing while making sure the arrows on the top of the fan (indicating air direction) point in the same direction as the arrows on the other fans. Make sure all four of the fan's rubber feet are in place.
5. Confirm that the fan is working properly before replacing the chassis cover.

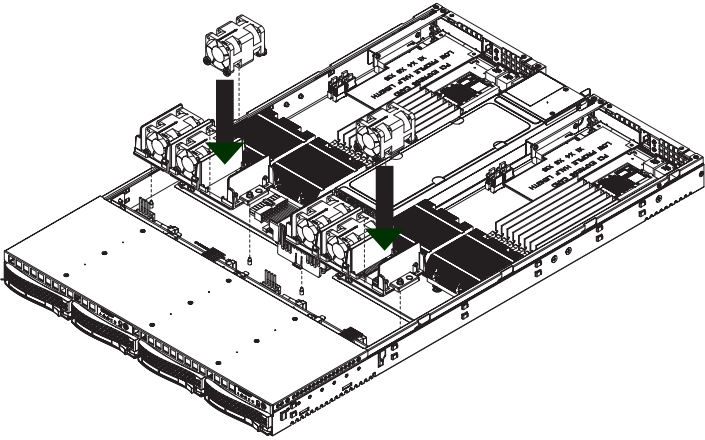

Figure 5-11: System Fan Placement

5-8 Power Supply

Depending on your chassis model, the SC808 Chassis has a 780, 980 or 1200 Watt power supply. This power supply is auto-switching capable. This enables it to automatically sense and operate at a 100v to 240v input voltage. An amber light will be illuminated on the power supply when the power is off. An illuminated green light indicates that the power supply is operating.

Power Supply Replacement

The SC808 chassis utilizes one power supply. In the unlikely event that the power supply unit must be replaced, the system will shut down. Replacement units can be ordered directly from Supermicro (see contact information in the Preface).

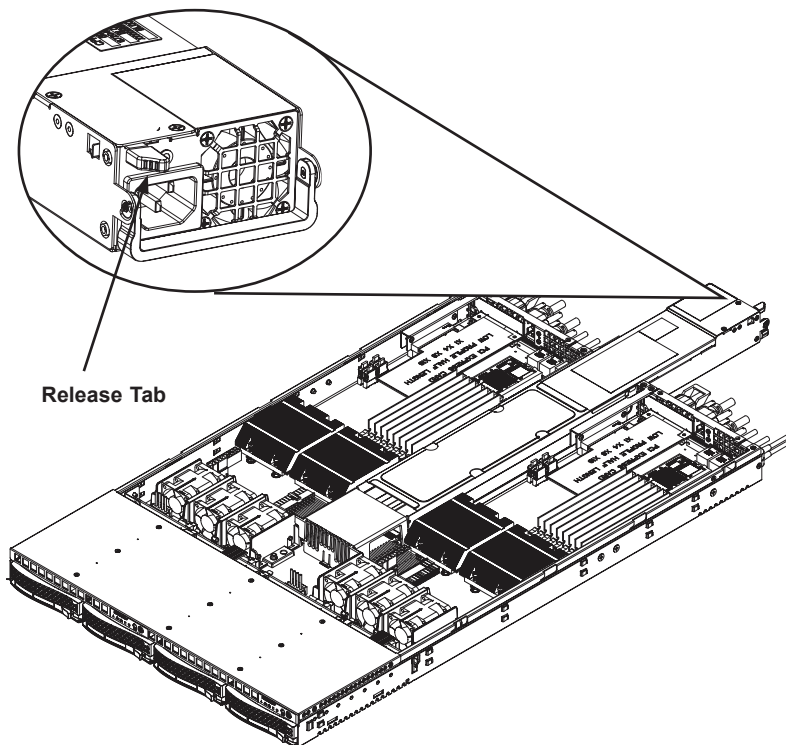

Figure 5-12: Changing the Power Supply

Changing the Power Supply

1. Power down the chassis and unplug the AC power cord.
2. Push the release tab (on the back of the power supply) as illustrated.
3. Pull the power supply out using the handle provided.
4. Push the new power supply module into the power bay until you hear a click.
5. Plug the AC power cord back into the module and power up the server.

Notes

Chapter 6

Rack Installation

6-1 Overview

This chapter provides a quick setup checklist to install the chassis into a rack. Following the steps in the order given should enable you to have the system installed within a minimal amount of time.

6-2 Unpacking the System

You should inspect the box the chassis was shipped in and note if it was damaged in any way. If the chassis itself shows damage you should file a damage claim with the carrier who delivered it.

Decide on a suitable location for the rack unit that will hold your chassis. It should be situated in a clean, dust-free area that is well ventilated. Avoid areas where heat, electrical noise and electromagnetic fields are generated. You will also need it placed near a grounded power outlet. Be sure to read the Rack and Server Precautions in the next section.

6-3 Preparing for Setup

The box your chassis was shipped in should include two sets of rail assemblies, two rail mounting brackets and the mounting screws you will need to install the system into the rack. Please read this section in its entirety before you begin the installation procedure outlined in the sections that follow.

Choosing a Setup Location

- Leave enough clearance in front of the rack to enable you to open the front door completely (~25 inches).
- Leave approximately 30 inches of clearance in the back of the rack to allow for sufficient airflow and ease in servicing.
- This product is for installation only in a Restricted Access Location (dedicated equipment rooms, service closets and the like).

Warnings and Precautions!

Rack Precautions

- Ensure that the leveling jacks on the bottom of the rack are fully extended to the floor with the full weight of the rack resting on them.
- In single rack installation, stabilizers should be attached to the rack.
- In multiple rack installations, the racks should be coupled together.
- Always make sure the rack is stable before extending a component from the rack.
- You should extend only one component at a time. Extending two or more simultaneously may cause the rack to become unstable.

General Server Precautions

- Review the electrical and general safety precautions that came with the components you are adding to your chassis.
- Determine the placement of each component in the rack *before* you install the rails.
- Install the heaviest server components on the bottom of the rack first, and then work up.
- Use a regulating uninterruptible power supply (UPS) to protect the server from power surges, voltage spikes and to keep your system operating in case of a power failure.
- Allow the hot-swappable hard drives and the power supply module to cool before touching them.
- Always keep the rack's front door and all panels and components on the servers closed when not servicing to maintain proper cooling.

Rack Mounting Considerations

Ambient Operating Temperature

If installed in a closed or multi-unit rack assembly, the ambient operating temperature of the rack environment may be greater than the ambient temperature of the room. Therefore, consideration should be given to installing the equipment in an environment compatible with the manufacturer's maximum rated ambient temperature (T_{mra}).

Reduced Airflow

Equipment should be mounted into a rack so that the amount of airflow required for safe operation is not compromised.

Mechanical Loading

Equipment should be mounted into a rack so that a hazardous condition does not arise due to uneven mechanical loading.

Circuit Overloading

Consideration should be given to the connection of the equipment to the power supply circuitry and the effect that any possible overloading of circuits might have on overcurrent protection and power supply wiring. Appropriate consideration of equipment nameplate ratings should be used when addressing this concern.

Reliable Ground

A reliable ground must be maintained at all times. To ensure this, the rack itself should be grounded. Particular attention should be given to power supply connections other than the direct connections to the branch circuit (i.e. the use of power strips, etc.).

6-4 Rack Mounting Instructions

This section provides information on installing the SC808 chassis into a rack unit with the rails provided. There are a variety of rack units on the market, which may mean the assembly procedure will differ slightly. You should also refer to the installation instructions that came with the rack unit you are using.

NOTE: This rail will fit a rack between 26" and 33.5" deep.

Identifying the Sections of the Rack Rails

The chassis package includes two rack rail assemblies in the rack mounting kit. Each assembly consists of two sections: an inner fixed chassis rail that secures directly to the server chassis and an outer fixed rack rail that secures directly to the rack itself.

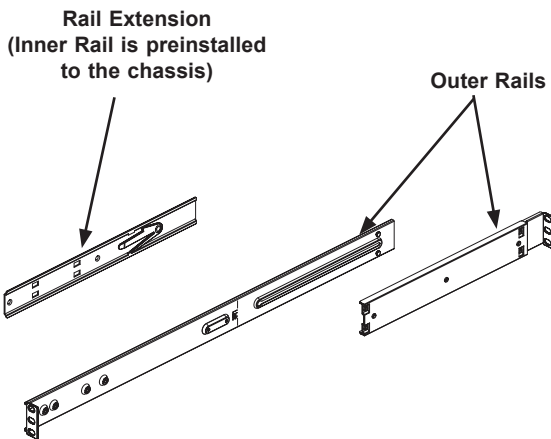

Figure 6-1: Identifying the Sections of the Rack Rails
(Right side rail shown)

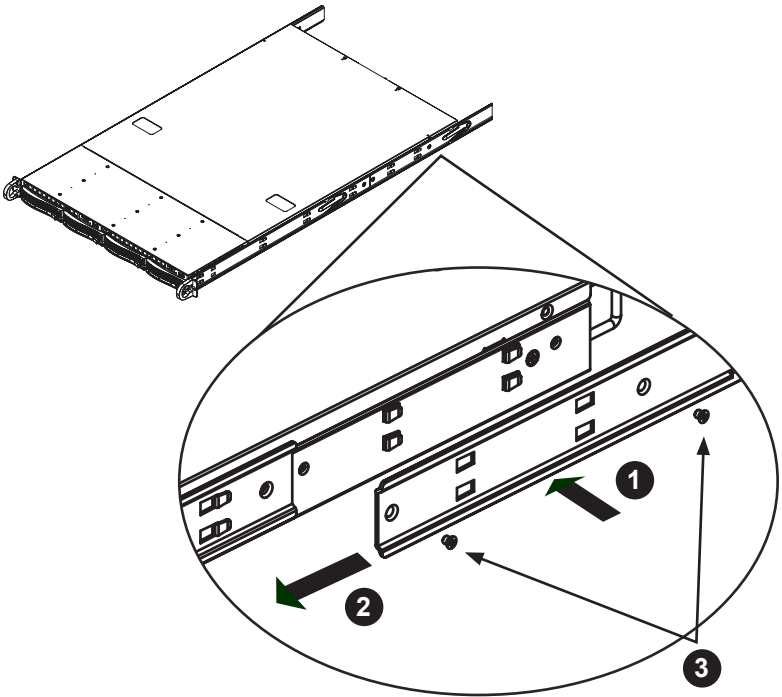

Figure 6-2: Installing the Inner Rail Extension

Installing the Inner Rail Extension

The SC808 chassis includes a set of inner rails in two sections: Inner rails and inner rail extensions. The inner rails are preattached and do not interfere with normal use of the chassis if you decide not to use a server rack. Attach the inner rail extension to stabilize the chassis within the rack.

Installing the Inner Rails

1. Place the inner rack extensions on the side of the chassis aligning the hooks of the chassis with the rail extension holes. Make sure the extension faces "outward" just like the preattached inner rail.
2. Slide the extension toward the front of the chassis.
3. Secure the chassis with two screws as illustrated.
4. Repeat steps 1-3 for the other inner rail extension.

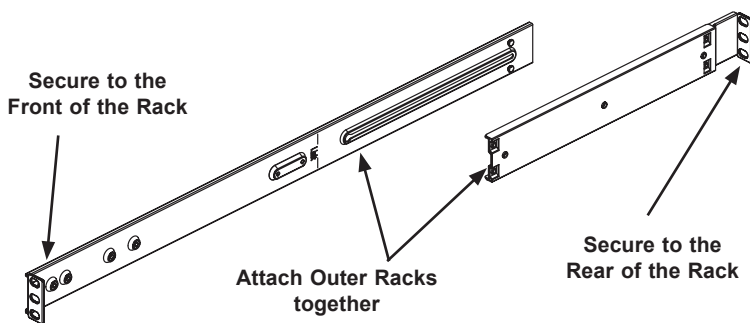

Figure 6-3: Assembling the Outer Rails

Installing the Outer Rails to the Rack

1. Attach the short bracket to the outside of the long bracket. You must align the pins with the slides. Also, both bracket ends must face the same direction.
2. Adjust both the short and long brackets to the proper distance so that the rail fits snugly into the rack.
3. Secure the long bracket to the front side of the outer rail with two M5 screws and the short bracket to the rear side of the outer rail with three M5 screws.
4. Repeat steps 1-4 for the left outer rail.

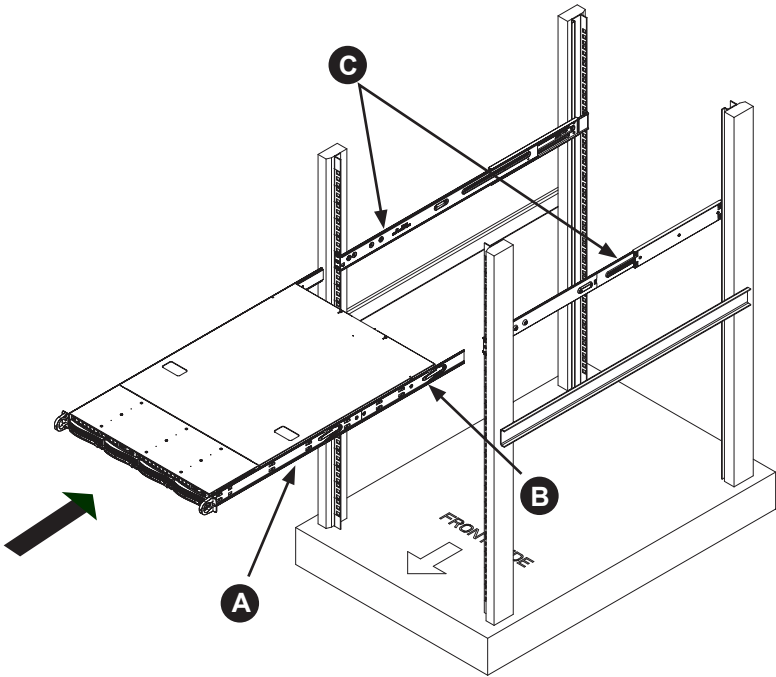

Figure 6-4: Installing the Chassis into a Rack

Installing the Chassis into a Rack

1. Confirm that chassis includes the inner rails (A) and rail extensions (B). Also, confirm that the outer rails (C) are installed on the rack.
2. Line chassis rails (A and B) with the front of the rack rails (C).
3. Slide the chassis rails into the rack rails, keeping the pressure even on both sides (you may have to depress the locking tabs when inserting). When the server has been pushed completely into the rack, you should hear the locking tabs "click".
4. (Optional) Insert and tightening the thumbscrews that hold the front of the server to the rack.

Notes

Appendix A

Cables, Screws, and other Accessories

A-1 Overview

This appendix lists supported cables for your chassis system. It only includes the most commonly used components and configurations. For more compatible cables, refer to the manufacturer of the motherboard you are using and our Web site at: www.supermicro.com.

A-2 Cables Included with SC808 Chassis (SAS/SATA)

SC808LT-780B, SC808T-780B, SC808T-980B			
Part #	Type	Length	Description
CBL-0087	Ribbon, Round	20"	16 pin to 16 pin ribbon cable for control panel
CBL-0212L	Wire	15 cm	Hard drive power extension cable, ST TO RA,
CBL-0160L	Cable	6'	Regional power cord
CBL-0201L	SATA	various	Set for 4 SATA Cables. Length varied to minimize airflow interference.

A-4 Compatible Cables

These cables are compatible with the SC808 chassis.

Alternate SAS/SATA Cables

Some compatible motherboards have different connectors. If your motherboard has only one SAS connector that the SAS/SATA cables must share, use one of the following cables. These cables must be purchased separately.

Cable Name: SAS Cable **Quantity:** 1

Part #: CBL-0175L

Alt. Name: "Big Four"

Description: This cable has one SFF-8484 (32 pin) connector on one end, and 4 SAS connectors (7 pins each) at the other. This cable connects from the host (motherboard or other controller) to the backplane SAS hard drive port.

Cable Name: SAS Cable **Quantity:** 1

Part #: CBL-0116L

Alt. Name: iPass or "Small Four"

Description: This cable has one ipass (SFF-8087/mini-sas) connector (36 pins) at one end, and four SAS connectors on the other end. This cable connects from the host (motherboard or other controller) to the backplane's SAS hard drive port.

Extending Power Cables

Although Supermicro chassis are designed with to be efficient and cost-effective, some compatible motherboards have power connectors located in different areas.

To use these motherboards, you may have to extend the power cables to the mother boards. To do this, use the following chart as a guide.

Power Cable Extenders		
Number of Pins	Cable Part #	Length
24 pin	CBL - 0042	7.9"(20 CM)
20 pin	CBL - 0059	7.9"(20 CM)
8 pin	CBL - 0062	7.9"(20 CM)
4 pin	CBL - 0060	7.9"(20 CM)

Front Panel to the Motherboard

The SC808 chassis includes a cable to connect the chassis front panel to the motherboard. If your motherboard uses a different connector, use the following list to find a compatible cable.

Front Panel to Motherboard Cable (Ribbon Cable)		
Number of Pins (Front Panel)	Number of Pins (Motherboard)	Cable Part #
16 pin	16 pin	CBL - 0049
16 pin	20 pin	CBL - 0048
20 pin	20 pin	CBL - 0047
16 pin	various*	CBL - 0068
20 pin	various*	CBL - 0067

* Split cables: Use these cables if your motherboard requires several different connections from the front panel.

A-5 Chassis Screws

The chassis and accessory box includes all of the screws needed to setup your chassis. This section includes descriptions of the most common screws used. Your chassis may not require all of the parts listed.

M/B



Pan head
6-32 x 5 mm
[0.197]

HARD DRIVE



Flat head
6-32 x 5 mm
[0.197]

DVD-ROM, CD-ROM, and FLOPPY DRIVE



Pan head
6-32 x 5 mm
[0.197]



Flat head
6-32 x 5 mm
[0.197]



Round head
3 x 5 mm
[0.197]



Round head
2.6 x 5 mm
[0.197]

RAIL



Flat head
M4 x 4 mm
[0.157]



Round head
M4 x 4 mm
[0.157]



Flat head
M5 x 12 mm [0.472]
Washer for M5



M/B STANDOFFS



M/B standoff
6-32 to 6-32



M/B (CPU) standoff
M5 to 6-32

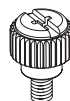

Thumb screw
6-32 x 5 mm [0.197]

Appendix B

SC808 Power Supply Specifications

This appendix lists power supply specifications for your chassis system.

SC808LT-780B and SC808T-780B	
	780W
MFR Part #	PWS-781-1S
Rated AC Voltage	180 - 240V 50 - 60Hz 5 - 3.5 Amp* *Power supply operates at 700W with a 100-140V input, and at 780W with a 180-240V input
+5V standby	4 Amp
+12V	58 - 65 Amp

SC808T-980B	
	980W
MFR Part #	PWS-981-1S
Rated AC Voltage	100 - 240V 50 - 60Hz 14- 6A max *Power supply operates at 900W with a 100-140V input and at 980W with a 180-240V input
+5V standby	4 Amp
+12V	59-65 Amp

SC808T-1200B	
1200W	
MFR Part #	PWS-1K21P-1R
Rated AC Input	100 - 140V 50 - 60Hz 7.5 - 11 Amp 180 - 240V 50 - 60Hz 5 - 8 Amp *Power supply operates at 1200W with a 100-140V input and at 1200W with a 180-240V input
+5V standby	4 Amp
+12V	74 Amp @ 100 - 140 100 Amp @ 180 - 240

Appendix C

SAS-808 Backplane Specifications

To avoid personal injury and property damage, carefully follow all the safety steps listed below when accessing your system or handling the components.

C-1 ESD Safety Guidelines

Electrostatic Discharge (ESD) can damage electronic components. To prevent damage to your system, it is important to handle it very carefully. The following measures are generally sufficient to protect your equipment from ESD.

- Use a grounded wrist strap designed to prevent static discharge.
- Touch a grounded metal object before removing a component from the antistatic bag.
- Handle the backplane by its edges only; do not touch its components, peripheral chips, memory modules or gold contacts.
- When handling chips or modules, avoid touching their pins.
- Put the card and peripherals back into their antistatic bags when not in use.

C-2 General Safety Guidelines

- Always disconnect power cables before installing or removing any components from the computer, including the backplane.
- Disconnect the power cable before installing or removing any cables from the backplane.
- Make sure that the backplane is securely and properly installed on the motherboard to prevent damage to the system due to power shortage.

C-3 An Important Note to Users

All images and layouts shown in this user's guide are based upon the latest PCB Revision available at the time of publishing. The card you have received may or may not look exactly the same as the graphics shown in this manual.

C-4 Introduction to the SAS-808 Backplane

The SAS-808 backplane has been designed to utilize the most up-to-date technology available, providing your system with reliable, high-quality performance.

This manual reflects SAS-808 Revision 1.00, the most current release available at the time of publication. Always refer to the Supermicro Web site at www.supermicro.com for the latest updates, compatible parts and supported configurations.

C-5 Front Connectors

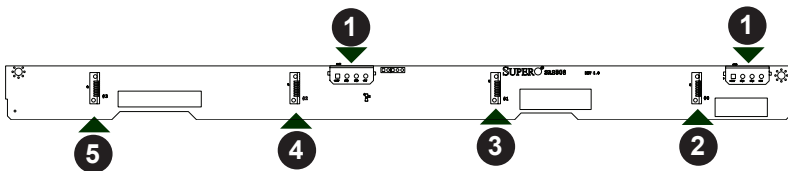

Figure C-1: Front Connectors

1. Power connectors (4-pin) JP10 and JP13
2. SAS Port #0 J5
3. SAS Port #1 J6
4. SAS Port #2 J7
5. SAS Port #3 J8

C-6 Front Connectors and Pin Definitions

1. Backplane Main Power Connectors

The 4-pin connectors, designated JP10 and JP13, provide power to the backplane. See the table on the right for pin definitions.

Backplane Main Power 4-Pin Connector	
Pin#	Definition
1	+12V
2 and 3	Ground
4	+5V

2. - 5. SAS Ports

The SAS ports are used to connect the SAS drive cables. The four ports are designated #0 - #4. Each port is also compatible with SATA drives.

C-7 Front Jumper Locations and Pin Definitions

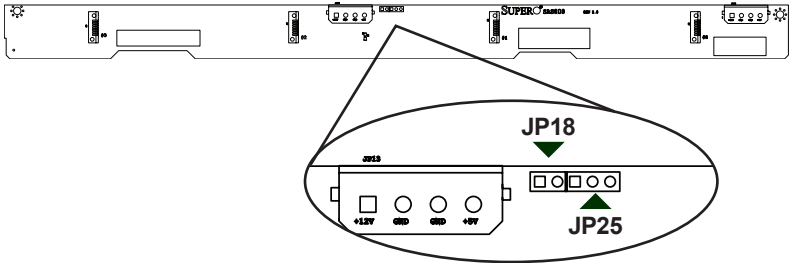
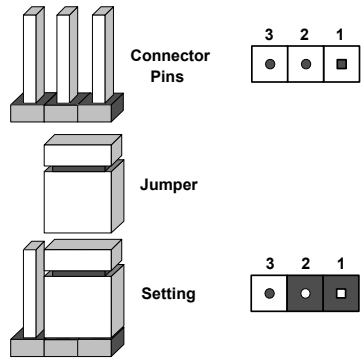

Figure C-2: Front Jumpers

Explanation of Jumpers

To modify the operation of the backplane, jumpers can be used to choose between optional settings. Jumpers create shorts between two pins to change the function of the connector. Pin 1 is identified with a square solder pad on the printed circuit board. Note: On two pin jumpers, "Closed" means the jumper is on and "Open" means the jumper is off the pins.



Jumper Settings		
Jumper	Jumper Settings	Note
JP18	Open: Default Closed: Reset	Buzzer reset*
JP25	Open: 45° Celcius C-2: 50° Celcius (Default) 2-3: 55° Celcius	Overheat temperature

*The buzzer sound indicates that a condition requiring immediate attention has occurred.

The buzzer alarm is triggered by the following condition:

A system temperature over 50° Celcius.

Front LED Indicators

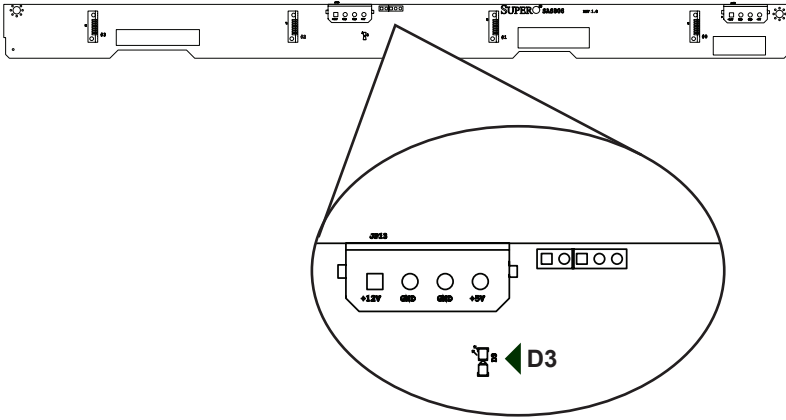

Figure C-3: Front LEDs

Front LED Indicators		
LED	State	Specification
D3	On	Overheat LED Indicator

2-4 Rear Connectors and LED Indicators

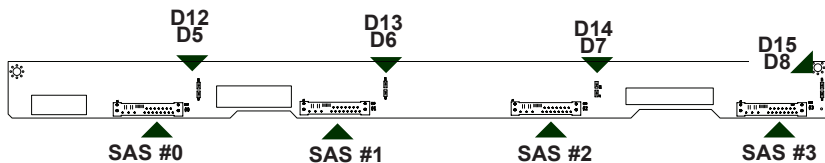

Figure C-4: Rear Connectors and LEDs

Rear SAS/SATA Connectors		
Rear Connector	Connector Number	SAS Drive Number
SAS #0	J1	SAS/SATA HDD #0
SAS #1	J2	SAS/SATA HDD #1
SAS #2	J3	SAS/SATA HDD #2
SAS #3	J4	SAS/SATA HDD #3

Rear LED Indicators	
Rear LED	Hard Drive Activity
SAS #0	D12
SAS #1	D13
SAS #2	D14
SAS #3	D15

Disclaimer (cont.)

The products sold by Supermicro are not intended for and will not be used in life support systems, medical equipment, nuclear facilities or systems, aircraft, aircraft devices, aircraft/emergency communication devices or other critical systems whose failure to perform be reasonably expected to result in significant injury or loss of life or catastrophic property damage. Accordingly, Supermicro disclaims any and all liability, and should buyer use or sell such products for use in such ultra-hazardous applications, it does so entirely at its own risk. Furthermore, buyer agrees to fully indemnify, defend and hold Supermicro harmless for and against any and all claims, demands, actions, litigation, and proceedings of any kind arising out of or related to such ultra-hazardous use or sale.