

iSCSI GbE to SAS/SATA II RAID SUBSYSTEM

Installation and Configuration Manual

Revision 1.0

P/N: PW0020000000343

Table of Contents

Preface	5
Before You Begin	6
Safety Guidelines	6
Controller Configurations	6
Packaging, Shipment and Delivery	6
Chapter 1 Introduction.....	7
1.1 Key Features.....	8
1.2 Terminology	9
1.3 RAID Levels	11
1.4 Volume Relationship Diagram.....	12
Chapter 2 Getting Started	13
2.1 Packaging, Shipment, and Delivery	13
2.2 Unpacking the Subsystem.....	13
2.3 Identifying Parts of the Subsystem	14
2.3.1 Front View	14
2.3.2 Rear View.....	16
2.4 Checklist before Starting.....	17
2.5 Connecting the iSCSI RAID Subsystem to the Network.....	18
2.6 Powering On	18
2.7 Installing Hard Drives	19
2.8 iSCSI Introduction	20
2.9 Management Methods	22
2.9.1 Web GUI	22
2.9.2 Console Serial Port	23
2.9.3 Remote Control – Secure Shell	23
2.10 Enclosure	24
2.10.1 LCD Control Module (LCM).....	24
2.10.2 System Buzzer.....	27
Chapter 3 Web GUI Guideline	28
3.1 The GUI Hierarchy	28
3.2 Login.....	29
3.2.1 Language	30
3.2.2 Status Indicators.....	30
3.3 Quick Install.....	31
3.4 System Configuration.....	32

3.4.1	System Setting	32
3.4.2	IP Address	33
3.4.3	Login Setting	34
3.4.4	Mail Setting	35
3.4.5	Notification Setting	36
3.5	iSCSI Configuration	39
3.5.1	Entity Property	39
3.5.2	NIC	40
3.5.3	Node	42
3.5.4	Session	44
3.5.5	CHAP Account	45
3.6	Volume Configuration	46
3.6.1	Volume Create Wizard	47
3.6.2	Physical Disk	49
3.6.3	RAID Group	52
3.6.4	Virtual Disk	54
3.6.5	Snapshot	58
3.6.6	Logical Unit	60
3.6.7	Example	62
3.7	Enclosure Management	67
3.7.1	SES Configuration	67
3.7.2	Hardware Monitor	68
3.7.3	Hard Drive S.M.A.R.T. Support	69
3.7.4	UPS	70
3.8	System Maintenance	71
3.8.1	System Information	71
3.8.2	Upgrade	72
3.8.3	Reset to Factory Default	72
3.8.4	Import and Export	73
3.8.5	Event Log	74
3.8.6	Reboot and Shutdown	74
3.9	Logout	75
Chapter 4 Advanced Operation		76
4.1	Rebuild	76
4.2	RG Migration	78
4.3	VD Extension	80
4.4	Snapshot / Rollback	81
4.4.1	Create Snapshot Volume	82
4.4.2	Auto Snapshot	84

4.4.3 Rollback.....	85
4.5 Disk Roaming.....	86
4.6 SAS JBOD Expansion	87
4.7 Support Microsoft MPIO and MC/S.....	89
Appendix.....	90
A. Certification list.....	90
B. Event Notifications.....	93
C. Known issues.....	97
D. Microsoft iSCSI Initiator	98
E. Installation steps for large volume (over 2TB)	100
F. MPIO and MC/S setup instructions	104
G. Trunking / LACP setup instructions	106

Preface

About this manual

This manual provides information regarding the quick installation and hardware features of the **RAID subsystem**. This document also describes how to use the storage management software. Information contained in the manual has been reviewed for accuracy, but not for product warranty because of the various environment/OS/settings. Information and specifications will be changed without further notice.

This manual uses section numbering for every topics being discussed for easy and convenient way of finding information in accordance with the user's needs. The following icons are being used for some details and information to be considered in going through with this manual:



NOTES:

These are notes that contain useful information and tips that the user must give attention to in going through with the subsystem operation.



IMPORTANT!

These are the important information that the user must remember.



WARNING!

These are the warnings that the user must follow to avoid unnecessary errors and bodily injury during hardware and software operation of the subsystem.



CAUTION:

These are the cautions that user must be aware to prevent damage to the equipment and its components.

Copyright

No part of this publication may be reproduced, stored in a retrieval system, or transmitted in any form or by any means, electronic, mechanical, photocopying, recording or otherwise, without the prior written consent.

Trademarks

All products and trade names used in this document are trademarks or registered trademarks of their respective holders.

Changes

The material in this document is for information only and is subject to change without notice.

Before You Begin

Before going through with this manual, you should read and focus to the following safety guidelines. Notes about the subsystem's controller configuration and the product packaging and delivery are also included.

Safety Guidelines

To provide reasonable protection against any harm on the part of the user and to obtain maximum performance, user is advised to be aware of the following safety guidelines particularly in handling hardware components:

Upon receiving of the product:

- ❖ Place the product in its proper location.
- ❖ To avoid unnecessary dropping out, make sure that somebody is around for immediate assistance.
- ❖ It should be handled with care to avoid dropping that may cause damage to the product. Always use the correct lifting procedures.

Upon installing of the product:

- ❖ Ambient temperature is very important for the installation site. It must not exceed 30°C. Due to seasonal climate changes; regulate the installation site temperature making it not to exceed the allowed ambient temperature.
- ❖ Before plugging-in any power cords, cables and connectors, make sure that the power switches are turned off. Disconnect first any power connection if the power supply module is being removed from the enclosure.
- ❖ Outlets must be accessible to the equipment.
- ❖ All external connections should be made using shielded cables and as much as possible should not be performed by bare hand. Using anti-static hand gloves is recommended.
- ❖ In installing each component, secure all the mounting screws and locks. Make sure that all screws are fully tightened. Follow correctly all the listed procedures in this manual for reliable performance.

Controller Configurations

This RAID subsystem supports single controller configuration.

Packaging, Shipment and Delivery

- ❖ Before removing the subsystem from the shipping carton, you should visually inspect the physical condition of the shipping carton.
- ❖ Unpack the subsystem and verify that the contents of the shipping carton are all there and in good condition.
- ❖ Exterior damage to the shipping carton may indicate that the contents of the carton are damaged.
- ❖ If any damage is found, do not remove the components; contact the dealer where you purchased the subsystem for further instructions.

Chapter 1 Introduction



The iSCSI RAID Subsystem

Host systems can connect to the iSCSI RAID subsystem using iSCSI protocol. The iSCSI RAID subsystem can be configured to any RAID level. The iSCSI RAID subsystem provides reliable data protection for servers and the RAID 6 function is available. The RAID 6 function allows two HDD failures without any impact on the existing data. Data can be recovered from the remaining data and parity drives. (Data can be recovered from the rest disks/drives.)

Snapshot-on-the-box is a fully usable copy of a defined collection of data that contains an image of the data as it appeared at the point in time, which means a point-in-time data replication. It provides consistent and instant copies of data volumes without any system downtime. The iSCSI RAID subsystem's snapshot-on-the-box can keep up to 32 snapshots for each data volumes. **Rollback** feature is provided for restoring the previously-snapshot data easily while continuously using the volume for further data access. The data access is regular as usual including read/write without any impact to end users. The "on-the-box" terminology implies that it does not require any proprietary agents installed at host side. The snapshot is taken at target side and done by iSCSI RAID controller. It will not consume any host CPU time thus the server is dedicated to the specific or other application. The snapshot copies can be taken manually or by schedule every hour or every day, depends on the settings.

The iSCSI RAID subsystem is the most cost-effective disk array subsystem with completely integrated high-performance and data-protection capabilities which meet or exceed the highest industry standards, and the best data solution for small/medium business users.

1.1 Key Features

- 4 x 1Gigabit Ethernet ports support independent access, fail-over or load-balancing (802.3ad port trunking, LACP)
- Supports iSCSI jumbo frame
- Supports Microsoft Multipath I/O (MPIO)
- Supports RAID levels 0, 1, 0+1, 3, 5, 6, 10, 30, 50, 60 and JBOD
- Local N-way mirror: Extension to RAID 1 level, N copies of the disk.
- Global and dedicated hot spare disks
- Write-through or write-back cache policy for different application usage
- Dedicated or shared cache allocation for volume usage
- Supports greater than 2TB per volume set (64-bit LBA support)
- Supports manual or scheduling volume snapshot (up to 512 snapshot)
- Snapshot and rollback mechanism
- Snapshot does not rely on host software
- Online volume migration with no system down-time
- Online volume expansion
- One logical volume can be shared by as many as 16 hosts
- Instant RAID volume availability and background initialization
- Support S.M.A.R.T for SATA drives
- SAS JBOD expansion support
- Microsoft VSS, VDS support
- Up to 1024 logical volumes in the system

1.2 Terminology

The document uses the following terms:

RAID	RAID is the abbreviation of “ R edundant A rray of I ndependent D isks”. There are different RAID levels with different degree of the data protection, data availability, performance to host environment.
PD	The Physical Disk belongs to the member disk of one specific volume group.
RG	Raid Group . A collection of removable media or physical disks. One RG consists of a set of VDs and owns one RAID level attribute.
VD	Virtual Disk . Each RG could be divided into several VDs. The VDs from one RG share the same RAID level, but may have different volume capacity.
CV	Cache Volume . The iSCSI RAID controller uses the on-board memory as cache. All RAM (except for the part which is occupied by the controller) can be used as cache.
LUN	Logical Unit Number . A logical unit number (LUN) is a unique identifier used on iSCSI connection which enables it to differentiate among separate devices (each one is a logical unit).
GUI	Graphic User Interface .
RAID width, RAID copy, RAID row (RAID cell in one row)	RAID width, copy and row are used to describe one VG. E.g.: <ol style="list-style-type: none">1. One 4-disk RAID 0 volume: RAID width= 4; RAID copy=1; RAID row=1.2. One 3-way mirroring volume: RAID width=1; RAID copy=3; RAID row=1.3. One RAID 10 volume over 3 4-disk RAID 1 volume: RAID width=1; RAID copy=4; RAID row=3.
WT	Write-Through cache write policy. A caching technique in which the completion of a write request is not signaled until data is safely stored on non-volatile media. Each data is synchronized in both data cache and the accessed physical disks.
WB	Write-Back cache write policy. A caching technique in which the completion of a write request is signaled as soon as the data is in cache and actual writing to non-volatile media occurs at a later time. It speeds up system write performance but needs to bear the risk where data may be inconsistent between data cache and the physical disks in one short time interval.

RO	Read-Only. The volume can be set as Read-Only.
DS	Dedicated Spare disks. The spare disks are only used by one specific VG. Others could not use these dedicated spare disks for any rebuilding purpose.
GS	Global Spare disks. GS is shared for rebuilding purpose. If some RGs need to use the global spare disks for rebuilding, they could get the spare disks out from the common spare disks pool for such requirement.
DC	Dedicated Cache.
GC	Global Cache.
DG	DeGraded mode. Not all of the RG's member disks are functioning, but the RG is able to respond to application read and write requests to its virtual disks.
S.M.A.R.T.	Self-Monitoring Analysis and Reporting Technology.
SAS	Serial Attached SCSI.
WWN	World Wide Name.
HBA	Host Bus Adapter.
SAF-TE	SCSI Accessed Fault-Tolerant Enclosures.
MPIO	Multi-Path Input/Output.
MC/S	Multiple Connections per Session
SES	SCSI Enclosure Services.
NIC	Network Interface Card.
iSCSI	Internet Small Computer Systems Interface.
LACP	Link Aggregation Control Protocol.
MTU	Maximum Transmission Unit.
CHAP	Challenge Handshake Authentication Protocol. An optional security mechanism to control access to an iSCSI storage system over the iSCSI data ports.
iSNS	Internet Storage Name Service.

1.3 RAID Levels

The subsystem can implement several different levels of RAID technology. RAID levels supported by the subsystem are shown below.

RAID Level	Description	Min. Drives
0	Block striping is provide, which yields higher performance than with individual drives. There is no redundancy.	1
1	Drives are paired and mirrored. All data is 100% duplicated on an equivalent drive. Fully redundant.	2
N-way mirror	Extension to RAID 1 level. It has N copies of the disk.	N
3	Data is striped across several physical drives. Parity protection is used for data redundancy.	3
5	Data is striped across several physical drives. Parity protection is used for data redundancy.	3
6	Data is striped across several physical drives. Parity protection is used for data redundancy. Requires N+2 drives to implement because of two-dimensional parity scheme	4
0 + 1	Mirroring of the two RAID 0 disk arrays. This level provides striping and redundancy through mirroring.	4
10	Striping over the two RAID 1 disk arrays. This level provides mirroring and redundancy through striping.	4
30	Combination of RAID levels 0 and 3. This level is best implemented on two RAID 3 disk arrays with data striped across both disk arrays.	6
50	RAID 50 provides the features of both RAID 0 and RAID 5. RAID 50 includes both parity and disk striping across multiple drives. RAID 50 is best implemented on two RAID 5 disk arrays with data striped across both disk arrays.	6
60	RAID 60 provides the features of both RAID 0 and RAID 6. RAID 60 includes both parity and disk striping across multiple drives. RAID 60 is best implemented on two RAID 6 disk arrays with data striped across both disk arrays.	8
JBOD	The abbreviation of "Just a Bunch Of Disks". JBOD needs at least one hard drive.	1

1.4 Volume Relationship Diagram

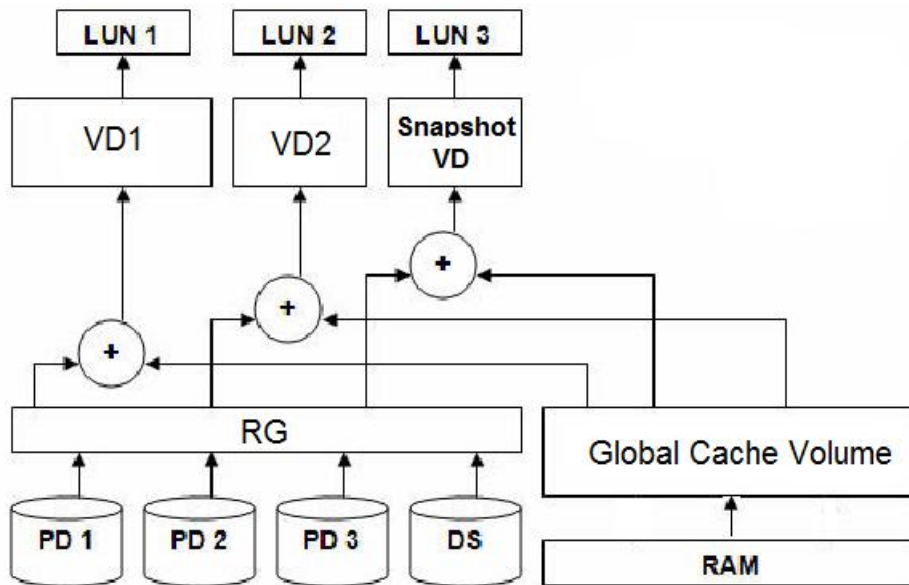

This is the design of volume structure of the iSCSI RAID subsystem. It describes the relationship of RAID components. One RG (RAID Group) is composed of several PDs (Physical Disks). One RG owns one RAID level attribute. Each RG can be divided into several VDs (Virtual Disks). The VDs in one RG share the same RAID level, but may have different volume capacity. Each VD will be associated with the Global Cache Volume to execute the data transaction. LUN (Logical Unit Number) is a unique identifier, in which users can access through SCSI commands.

Chapter 2 Getting Started

2.1 Packaging, Shipment, and Delivery

- ❖ Before removing the subsystem from the shipping carton, you should visually inspect the physical condition of the shipping carton.
- ❖ Unpack the subsystem and verify that the contents of the shipping carton are all there and in good condition.
- ❖ Exterior damage to the shipping carton may indicate that the contents of the carton are damaged.
- ❖ If any damage is found, do not remove the components; contact the dealer where you purchased the subsystem for further instructions.

2.2 Unpacking the Subsystem

The package contains the following items:

- iSCSI RAID subsystem
- Two power cords
- Five Ethernet LAN cables
- One external null modem cable
- Installation Reference Guide
- Spare screws, etc.



If any of these items are missing or damaged, please contact your dealer or sales representative for assistance.

2.3 Identifying Parts of the Subsystem

The illustrations below identify the various parts of the subsystem.

2.3.1 Front View

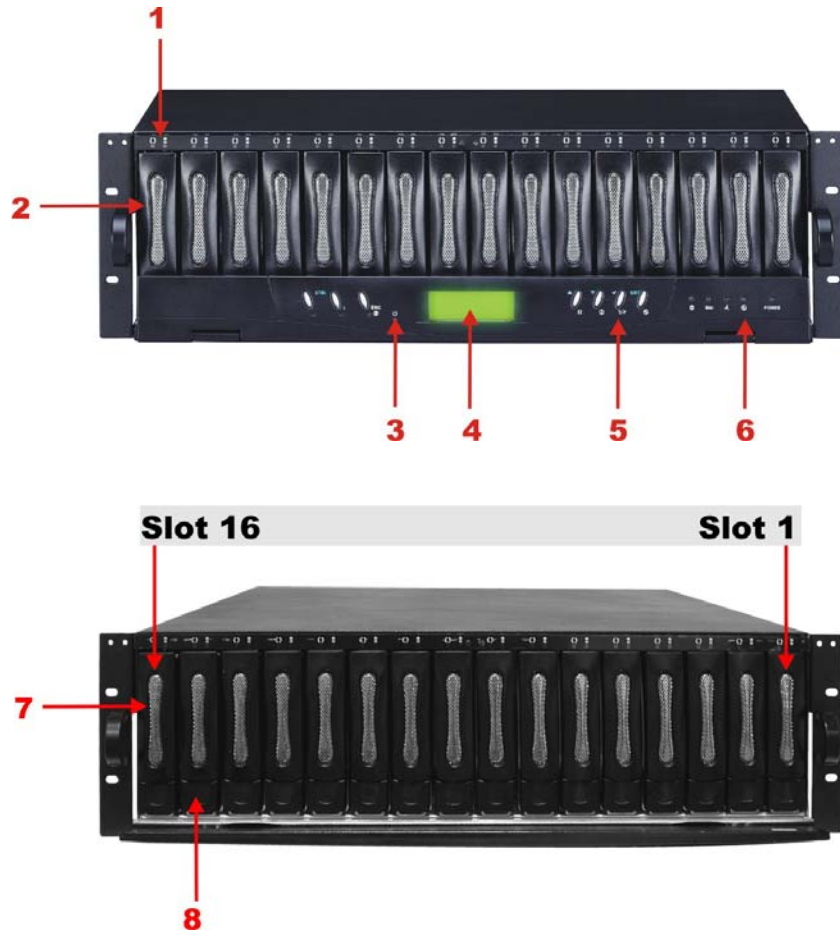

1. HDD Status Indicator



Parts	Function
HDD Status LEDs ● ✕	Green LED indicates power is on and hard drive status is good for this slot. If hard drive defected in this slot or the hard drive is failure, the LED is orange.
HDD Access LEDs	These LED will blink blue when the hard drive is being accessed.

2. HDD Trays 1 ~ 16 (From left to right)



3. Access LED

The LED will be blinking blue when subsystem is busy or data is being accessed.





4. LCD Display Panel

5. LCM (LCD Control Module) - Smart Front Panel Function Buttons

The LCM provides menu options to configure the iSCSI RAID subsystem. If you are configuring the subsystem using the Front Panel, please press the controller button to configure your RAID subsystem.

Parts	Function
Up and Down Arrow buttons 	Use the Up or Down arrow keys to go through the information on the LCD screen. This is also used to move between each menu when you configure the subsystem.
Select button 	This is used to enter the option you have selected.
Exit button EXIT	Press this button to return to the previous menu.

6. Environment Status LEDs

Parts	Function
Power LED	Green LED indicates power is ON.
Power Fail LED 	If a redundant power supply unit fails, this LED will turn to RED and alarm will sound.
Fan Fail LED 	When a fan fails, this LED will turn red and an alarm will sound.
Over Temperature LED 	If temperature irregularities in the system occurs (HDD slot temperature over 45°C), this LED will turn RED and alarm will sound.
Voltage Warning LED 	An alarm will sound warning of a voltage abnormality and this LED will turn red.
Access LED 	This LED will blink blue when the RAID controller is busy / active.

7. Tray Lever

8. Tray Latch

2.3.2 Rear View

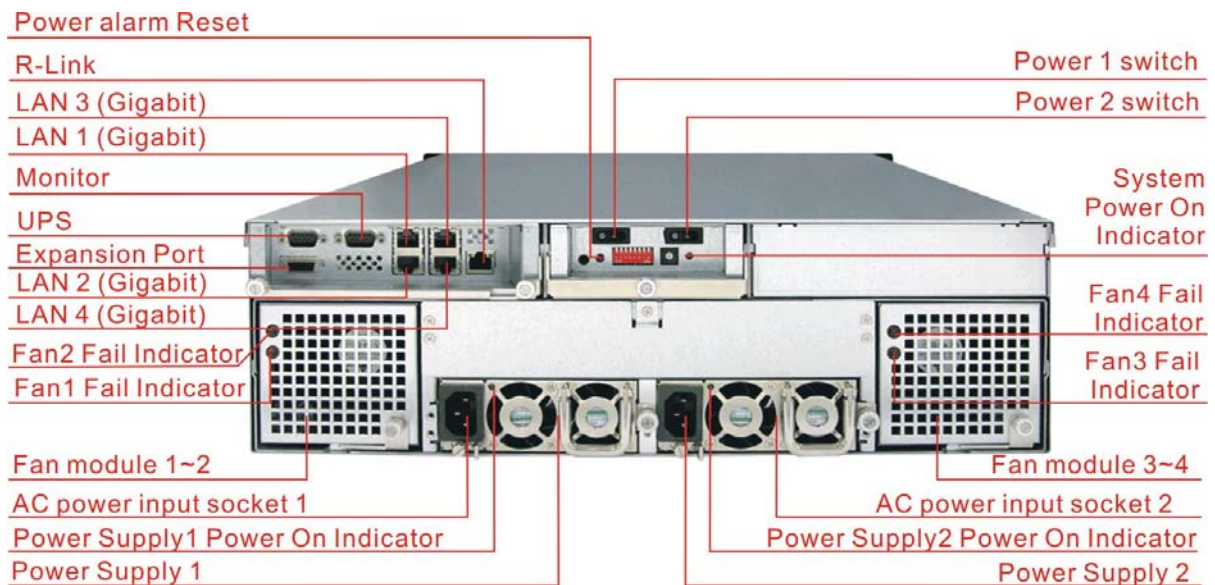

1. Power Supply Alarm Reset button

You can push the power supply reset button to stop the power supply buzzer alarm.

2. Uninterrupted Power Supply (UPS) Port (APC Smart UPS only)

The subsystem may come with an optional UPS port allowing you to connect an APC Smart UPS device. Connect the cable from the UPS device to the UPS port located at the rear of the subsystem. This will automatically allow the subsystem to use the functions and features of the UPS.

3. R-Link Port: Remote Link through RJ-45 Ethernet for remote management

The subsystem is equipped with one 10/100 Ethernet RJ45 LAN port for remote configuration and monitoring. You use web browser to manage the RAID subsystem through Ethernet.

4. LAN Ports (Gigabit)

The subsystem is equipped with four LAN data ports for iSCSI connection.

5. Monitor Port

The subsystem is equipped with a serial monitor port allowing you to connect a PC or terminal.

6. Fan Fail indicator

If a fan fails, this LED will turn red.

7. Cooling Fan module

Two blower fans are located at the rear of the subsystem. They provide sufficient airflow and heat dispersion inside the chassis. In case a fan fails to function, the "  " Fan fail LED will turn red and an alarm will sound.

8. Power Supply Power On Indicator

Green LED indicates power is on.

9. System Power On Indicator

Green LED indicates power is on.

10. Power Supply Unit 1 ~ 2

Two power supplies (power supply 1 and power supply 2) are located at the rear of the subsystem. Turn on the power of these power supplies to power-on the subsystem. The "power" LED at the front panel will turn green.

If a power supply fails to function or a power supply was not turned on, the "  " Power fail LED will turn red and an alarm will sound.

2.4 Checklist before Starting

Before starting, check or prepare the following items.

- Check "**Certification list**" in Appendix A to confirm the hardware setting is fully supported.
- Read the latest release note before upgrading. Release note accompany with release firmware.
- A server with a NIC or iSCSI HBA.
- CAT 5e, or CAT 6 network cables for management port and iSCSI data ports. Recommend CAT 6 cables for best performance.
- Prepare storage system configuration plan.
- Management and iSCSI data ports network information. When using static IP, please prepare static IP addresses, subnet mask, and default gateway.
- Gigabit LAN switches. (recommended) Or Gigabit LAN switches with VLAN/LCAP/Trunking. (optional)
- CHAP security information, including CHAP username and secret. (optional)
- Setup the hardware connection before powering on the server(s) and the iSCSI RAID system.

2.5 Connecting the iSCSI RAID Subsystem to the Network

To connect the iSCSI unit to the network, insert the network cable that came with the unit into the network port (LAN1) at the back of iSCSI unit. Insert the other end into a Gigabit BASE-T Ethernet connection on your network hub or switch. You may connect the other network ports if needed.

For remote management of iSCSI RAID subsystem, use another network cable to connect the R-Link port to your network.

2.6 Powering On

1. Plug in all the power cords into the AC Power Input Socket located at the rear of the subsystem.

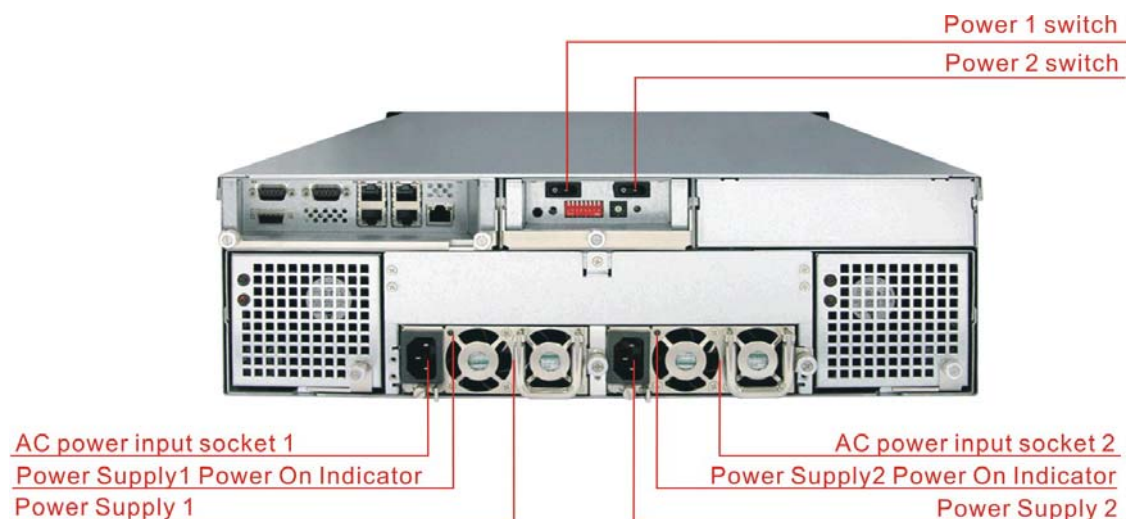

2. Press Power Switch 1 and 2 to turn on the subsystem.
3. The Power LED on the front Panel will turn green.

2.7 Installing Hard Drives

This section describes the physical locations of the hard drives supported by the subsystem and give instructions on installing a hard drive. The subsystem supports hot-swapping allowing you to install or replace a hard drive while the subsystem is running.

- a. Pull out an empty disk tray. Pull the handle outwards to remove the carrier from the enclosure.
- b. Take off the bracket before installing hard drive.

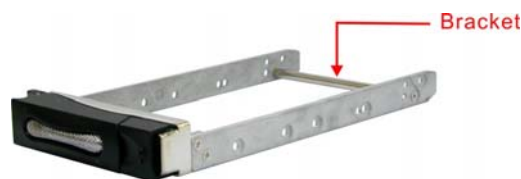

- c. Place the hard drive in the disk tray.
- d. Install the mounting screws on each side to secure the drive in the tray.

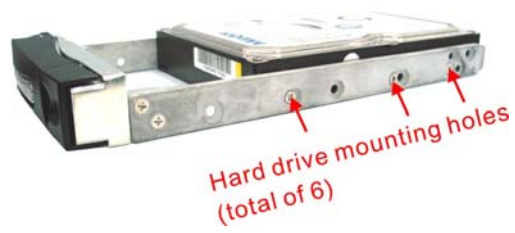

- e. Slide the tray into a slot until it clicks into place. The HDD status LED will turn green if subsystem is on.



- f. Press the lever in until you hear the latch click into place.
- g. If the HDD power LED did not turn green, check if the hard drive is in good condition. If the hard drive is not being accessed, the HDD access LED will not illuminate.

2.8 iSCSI Introduction

iSCSI (Internet SCSI) is a protocol which encapsulates SCSI (Small Computer System Interface) commands and data in TCP/IP packets for linking storage devices with servers over common IP infrastructures. iSCSI provides high performance SANs over standard IP networks like LAN, WAN or the Internet.

IP SANs are true SANs (Storage Area Networks) which allow few of servers to attach to an infinite number of storage volumes by using iSCSI over TCP/IP networks. IP SANs can scale the storage capacity with any type and brand of storage system. In addition, using any type of network (Ethernet, Fast Ethernet, Gigabit Ethernet) and combining operating systems (Microsoft Windows, Linux, Solaris, ...etc.) within the SAN network. IP-SANs also include mechanisms for security, data replication, multi-path and high availability.

Storage protocol, such as iSCSI, has "two ends" in the connection. These ends are the initiator and the target. In iSCSI we call them iSCSI initiator and iSCSI target. The iSCSI initiator requests or initiates any iSCSI communication. It requests all SCSI operations like read or write. An initiator is usually located on the host/server side (either an iSCSI HBA or iSCSI SW initiator).

The iSCSI target is the storage device itself or an appliance which controls and serves volumes or virtual volumes. The target is the device which performs SCSI commands or bridges it to an attached storage device. iSCSI targets can be disks, tapes, RAID arrays, tape libraries, and etc.

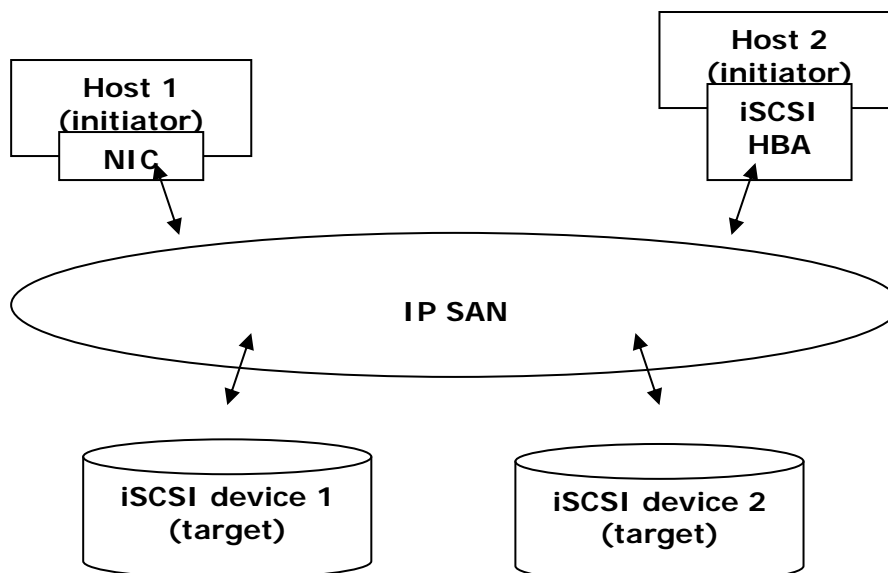

The host side needs an iSCSI initiator. The initiator is a driver which handles the SCSI traffic over iSCSI. The initiator can be software or hardware (HBA). Please refer to the certification list of iSCSI HBA(s) in Appendix A. OS native initiators or other software initiators use the standard TCP/IP stack and Ethernet hardware, while iSCSI HBA(s) use their own iSCSI and TCP/IP stacks on board.

Hardware iSCSI HBA(s) would provide its initiator tool. Please refer to the vendors' HBA user manual. **Microsoft**, **Linux** and **Mac** provide software iSCSI initiator driver. Below are the available links:

1. Link to download the Microsoft iSCSI software initiator:

<http://www.microsoft.com/downloads/details.aspx?FamilyID=12cb3c1a-15d6-4585-b385-befd1319f825&DisplayLang=en>

Please refer to Appendix D for Microsoft iSCSI initiator installation procedure.

2. Linux iSCSI initiator is also available. For different kernels, there are different iSCSI drivers. If you need the latest Linux iSCSI initiator, please visit Open-iSCSI project for most update information. Linux-iSCSI (sfnet) and Open-iSCSI projects merged in April 11, 2005.

Open-iSCSI website: <http://www.open-iscsi.org/>

Open-iSCSI README: <http://www.open-iscsi.org/docs/README>

Features: <http://www.open-iscsi.org/cgi-bin/wiki.pl/Roadmap>

Support Kernels: http://www.open-iscsi.org/cgi-bin/wiki.pl/Supported_Kernels

Google groups: <http://groups.google.com/group/open-iscsi/threads?gvc=2>

<http://groups.google.com/group/open-iscsi/topics>

Open-iSCSI Wiki: <http://www.open-iscsi.org/cgi-bin/wiki.pl>

3. ATTO iSCSI initiator is available for Mac.

Website: <http://www.attotech.com/xtend.html>

2.9 Management Methods

There are three management methods to manage the iSCSI RAID subsystem described as follows:

2.9.1 Web GUI

The iSCSI RAID subsystem supports graphical user interface to manage the system. Be sure to connect LAN cable to your R-Link port. The default setting of management port IP is DHCP and the DHCP address displays on LCM; user can check LCM for the IP first, then open the browser and type the DHCP address: (The DHCP address is dynamic and user may need to check every time after reboot again.) When DHCP service is not available, the system uses zero config (Zeroconf) to get an IP address.

E.g., on LCM. The iSCSI RAID subsystem gets a DHCP address 192.168.10.50 from DHCP server.

192.168.10.50 iSCSI-Model
--

<http://192.168.10.50> or <https://192.168.10.50> (**https: connection with encrypted Secure Sockets Layer (SSL). Please be aware of the https function is slower than http.**)

Click any function at the first time; it will pop up a dialog box to authenticate current user.

Login name: **admin**
Default password: **00000000**

Or login with the read-only account which only allows seeing the configuration and cannot change setting.

Login name: **user**
Default password: 1234

2.9.2 Console Serial Port

Use NULL modem cable to connect console port.

The console setting is baud rate: **115200**, 8 bits, 1 stop bit, and no parity.

Terminal type: **vt100**

Login name: **admin**

Default password: **00000000**

2.9.3 Remote Control – Secure Shell

SSH (secure shell) is required for remote login. The SSH client software is available at the following web site:

SSHWinClient WWW: <http://www.ssh.com/>

Putty WWW: <http://www.chiark.greenend.org.uk/>

Host name: **192.168.10.50 (Please check your DHCP address for this field.)**

Login name: **admin**

Default password: **00000000**



NOTE: This iSCSI RAID Series only support SSH for remote control. For using SSH, the IP address and the password is required for login.

2.10 Enclosure

2.10.1 LCD Control Module (LCM)

There are four buttons to control the LCM. These are:

▲(Up) ▼(Down) EXIT(Escape) ✓ (Enter)

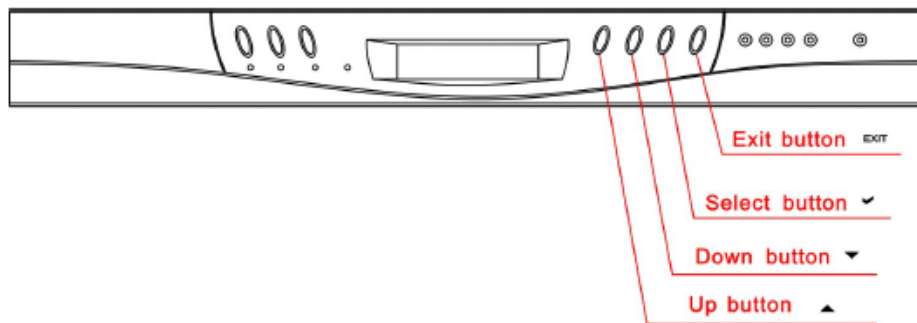

After booting up the system, the following screen shows management port IP and model name:

```
192.168.10.50  
iSCSI-Model
```

Press "EXIT", the LCM functions "Alarm Mute", "Reset/Shutdown", "Quick Install", "View IP Setting", "Change IP Config" and "Reset to Default" will rotate by pressing ▲ (up) and ▼ (down).

When there is WARNING or ERROR level of event happening, the LCM also shows the event log to give users event information from front panel.

The following table is the function description of LCM menus.

System Info	Displays System information.
Alarm Mute	Mute alarm when error occurs.
Reset/Shutdown	Reset or shutdown controller.
Quick Install	Quick three steps to create a volume. Please refer to next chapter for operation in web UI.
Volume Wizard	Smart steps to create a volume. Please refer to next chapter for operation in web UI.
View IP Setting	Display current IP address, subnet mask, and gateway.
Change IP Config	Set IP address, subnet mask, and gateway. There are 2 selections, DHCP (Get IP address from DHCP server) or set static IP.
Reset to Default	Reset to default sets password to default: 00000000 , and set IP address to default as DHCP setting. Default IP address: 192.168.10.50 (DHCP) Default subnet mask: 255.255.255.0 Default gateway: 192.168.10.254

The following is LCM menu hierarchy.

proIPS ▲▼	[System Info.]	[Firmware Version x.x.x]			
		[RAM Size xxx MB]			
	[Alarm Mute]	[▲Yes No▼]			
	[Reset/Shutdown]	[Reset]	[▲Yes No▼]		
		[Shutdown]	[▲Yes No▼]		
	[Quick Install]	RAID 0 RAID 1 RAID 3 RAID 5 RAID 6 RAID 0+1 xxx GB	[Apply The Config]	[▲Yes No▼]	
	[Volume Wizard]	[Local] RAID 0 RAID 1 RAID 3 RAID 5 RAID 6 RAID 0+1	[Use default algorithm]	[Volume Size] xxx GB	[Apply The Config] [▲Yes No▼]
		[JBOD x] ▲▼ RAID 0 RAID 1 RAID 3 RAID 5 RAID 6 RAID 0+1	[new x disk] ▲▼ xxx BG	Adjust Volume Size	[Apply The Config] [▲Yes No▼]
	[View IP Setting]	[IP Config] [Static IP]			
		[IP Address] [192.168.010.050]			
		[IP Subnet Mask] [255.255.255.0]			
		[IP Gateway] [192.168.010.254]			
	[Change IP Config]	[DHCP]	[▲Yes No▼]		
		[Static IP]	[IP Address]	Adjust IP address	
			[IP Subnet Mask]	Adjust Submask IP	
[IP Gateway]			Adjust Gateway IP		
[Apply IP Setting]			[▲Yes No▼]		
[Reset to Default]	[▲Yes No▼]				



CAUTION! Before power off, it is better to execute "Shutdown" to flush the data from cache to physical disks.

2.10.2 System Buzzer

The system buzzer features are described in the following:

1. The system buzzer alarms 1 second when system boots up successfully.
2. The system buzzer alarms continuously when an error level event happens. The alarm will be stopped after mute.
3. The alarm will be muted automatically when the error situation is resolved. E.g.: When RAID 5 is degraded, an alarm rings immediately. After user changes/adds one physical disk for rebuilding, and when the rebuilding is done, the alarm will be muted automatically.

Chapter 3 Web GUI Guideline

3.1 The GUI Hierarchy

The below table is the hierarchy of the management GUI.

Quick installation	→ Step 1 / Step 2 / Confirm
System configuration	
System setting	→ System name / Date and time
IP address	→ MAC address / Address / DNS / port
Login setting	→ Login configuration / Admin password / User password
Mail setting	→ Mail
Notification setting	→ SNMP / Messenger / System log server / Event log filter
iSCSI configuration	
Entity property	→ Entity name / iSNS IP
NIC	→ Aggregation / IP settings for iSCSI ports / Become default gateway / Enable jumbo frame
Node	→ Create / Authenticate / Rename / User / Delete
Session	→ Session information / Delete
CHAP account	→ Create / Modify user information / Delete
Volume configuration	
Volume create wizard	Step 1 / Step 2 / Step 3 / Step 4 / Confirm
Physical disk	→ Set Free disk / Set Global spare / Set Dedicated spare / Set property / More information
RAID group	→ Create / Migrate / Activate / Deactivate / Scrub / Delete / Set disk property / More information
Virtual disk	→ Create / Extend / Scrub / Delete / Set property / Attach LUN / Detach LUN / List LUN / Set snapshot space / Cleanup snapshot / Take snapshot / Auto snapshot / List snapshot / More information
Snapshot	→ Cleanup snapshot / Auto snapshot / Take snapshot / Export / Rollback / Delete
Logical unit	→ Attach / Detach
Enclosure management	
SES configuration	→ Enable / Disable
Hardware monitor	→ Auto shutdown
S.M.A.R.T.	→ S.M.A.R.T. information (Only for SATA disks)
UPS	→ UPS Type / Shutdown battery level / Shutdown delay / Shutdown UPS
Maintenance	
System information	→ System information
Upgrade	→ Browse the firmware to upgrade / Export configuration

-
- Reset to default** → Sure to reset to factory default?
 - Import and export** → Import/Export / Import file
 - Event log** → Download / Mute / Clear
 - Reboot and shutdown** → Reboot / Shutdown

Logout

Sure to logout?

3.2 Login

The iSCSI RAID subsystem supports graphical user interface (GUI) to operate the system. Be sure to connect the LAN cable. The default IP setting is **DHCP**; open the browser and enter:

http://192.168.10.50 (Please check the DHCP address first on LCM)

Click any function at the first time; it will pop up a dialog window for authentication.

Login name: **admin**

Default password: 00000000



After login, you can choose the function blocks on the left side of window to do configuration.

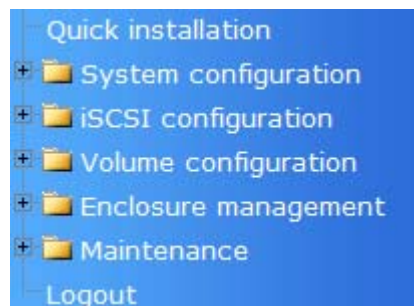

3.2.1 Language







Before clicking the Login button, you can change the GUI language if needed. There are 4 options to select: English, Simplified Chinese, German, and French.



3.2.2 Status Indicators

There are six indicators at the top-right corner.



1.  **RAID light:** Green means RAID is working well. Red represents RAID failure.
2.  **Temperature light:** Green is normal. Red represents abnormal temperature.
3.  **Voltage light:** Green is normal. Red represents abnormal voltage status.
4.  **UPS light:** Green is normal. Red represents abnormal UPS status.
5.  **Fan light:** Green is normal. Red represents abnormal fan status.
6.  **Power light:** Green is normal. Red represents abnormal power status.

3.3 Quick Install

It is easy to use “**Quick install**” to create a volume. It uses all available physical disks to create a RG; the system will calculate maximum spaces on RAID levels 0/1/3/5/6/0+1. “**Quick install**” will occupy all residual RG space for one VD, and it has no space for snapshot and spare. If snapshot is needed, please create volumes manually, and refer to Section 4.4 for more detail. If some physical disks are used in other RGs, “**Quick install**” can not be run because the operation is valid only when all physical disks in this system are free.

Step 1: Click “**Quick install**”, then choose the RAID level. After choosing the RAID level, then click “ ”. It will link to another page.

/ Quick installation / Step 1

RAID enclosure : **Local**

RAID level :

- RAID 0 (271 GB) -

- RAID 0 (271 GB) -

- RAID 1 (33 GB) -

- RAID 3 (237 GB) -

- RAID 5 (237 GB) -

- RAID 6 (203 GB) -

- RAID 0+1 (135 GB) -

Step 2: Confirm page. Click “ ” if all setups are correct. Then a VD will be created.

Done. You can start to use the system now.

No.	Name	Size (GB)	Right	Priority	Bg rate	Status	Health	R %	RAID	#LUN	Snapshot (MB)	#Snapshot	RG name
1	QUICK11862	271	WB	HI	4	Online	Optimal		RAID 0	1	0/0	0	QUICK16150

A RAID 0 Virtual disk with the VD name “QUICK16150”, named by the system itself, with the total available volume size of 271GB.

3.4 System Configuration

“System configuration” is designed for setting up the “System setting”, “IP address”, “Login setting”, “Mail setting”, and “Notification setting”.

/ System configuration	
System setting	System name for identification System time for event log
IP address	Internet Protocol(IP) address for remote administration
Login setting	Configuration for auto logout and login lock Administrator's password
Mail setting	Alert by e-mail
Notification setting	Alert via Simple Network Management Protocol(SNMP) Transmits net send and alerter service messages between clients and servers Alert to remote system log server

3.4.1 System Setting

“System setting” can be used to set system name and date. Default “System name” is composed of model name and serial number of this system, e.g.: iSCSI-Model-A6D299.

/ System configuration / System setting	
System name	
System name :	iSCSI-Model-A6D299
Date and time	
<input type="checkbox"/> Change date and time	
Current time :	2008/9/26 12:32:23
Time zone :	(GMT) Greenwich Mean Time : Dublin, Edinburgh, Lisbon, London ▾
<input checked="" type="radio"/> Setup date and time manually	
Date :	2008 ▾ / 9 ▾ / 26 ▾
Time :	12 ▾ : 3 ▾ : 4 ▾
<input type="radio"/> NTP	
Server :	

Check **“Change date and time”** to set up the current date, time, and time zone before using or synchronize time from NTP (Network Time Protocol) server.

3.4.2 IP Address

“IP address” can be used to change IP address remote administration usage. There are 2 options, DHCP (Get IP address from DHCP server) or static IP. The default setting is DHCP. User can change the HTTP, HTTPS, and SSH port number when the default port number is not allowed on host/server.

/ System configuration / IP address	
MAC address	
MAC address :	00:13:78:A6:D2:99
Address	
<input type="radio"/>	DHCP
<input checked="" type="radio"/>	Static
Address :	192.168.0.14
Mask :	255.255.255.0
Gateway :	192.168.0.254
DNS	
DNS :	192.168.0.11
Port	
HTTP port :	80
HTTPS port :	443
SSH port :	22

3.4.3 Login Setting

“**Login setting**” can set single admin, auto logout time and Admin/User password. The single admin can prevent multiple users access the same controller at the same time.

1. **Auto logout:** The options are (1) Disable; (2) 5 minutes; (3) 30 minutes; (4) 1 hour. The system will log out automatically when user is inactive for a period of time.
2. **Login lock:** Disable/Enable. When the login lock is enabled, the system allows only one user to login or modify system settings.

Login configuration	
Auto logout :	- Disable -
Login lock :	- Disable -

Admin password	
<input type="checkbox"/> Change admin password	
Old password :	<input type="password"/>
Password :	<input type="password"/>
Confirm :	<input type="password"/>

User password	
<input type="checkbox"/> Change user password	
Password :	<input type="password"/>
Confirm :	<input type="password"/>

Check “**Change admin password**” or “**Change user password**” to change admin or user password. The maximum length of password is 12 characters.

3.4.4 Mail Setting

“Mail setting” can accept at most 3 mail-to address entries for receiving the event notification. Some mail servers would check “Mail-from address” and need authentication for anti-spam. Please fill the necessary fields and click “Send test mail” to test whether email functions are available or working. User can also select which levels of event logs are needed to be sent via Mail. Default setting only enables ERROR and WARNING event logs.

/ System configuration / Mail setting

Mail

Mail-from address :	<input type="text" value="mailman@yourcompany.com"/>
Mail-to address 1 :	<input type="text"/>
Send events 1 :	<input type="checkbox"/> INFO <input checked="" type="checkbox"/> WARNING <input checked="" type="checkbox"/> ERROR
Mail-to address 2 :	<input type="text"/>
Send events 2 :	<input type="checkbox"/> INFO <input checked="" type="checkbox"/> WARNING <input checked="" type="checkbox"/> ERROR
Mail-to address 3 :	<input type="text"/>
Send events 3 :	<input type="checkbox"/> INFO <input checked="" type="checkbox"/> WARNING <input checked="" type="checkbox"/> ERROR
<input type="checkbox"/> SMTP relay	
SMTP server :	<input type="text"/>
Authentication :	<input type="text" value="None"/>
Account :	<input type="text"/>
Password :	<input type="text"/>
Confirm :	<input type="text"/>

3.4.5 Notification Setting

“**Notification setting**” can be used to set up SNMP trap for alerting via SNMP, pop-up message via Windows messenger (not MSN), alert via syslog protocol, and event log filter.

SNMP	
SNMP trap address 1 :	<input type="text"/>
SNMP trap address 2 :	<input type="text"/>
SNMP trap address 3 :	<input type="text"/>
Community :	<input type="text" value="public"/>
Send events :	<input checked="" type="checkbox"/> INFO <input type="checkbox"/> WARNING <input type="checkbox"/> ERROR

Messenger	
Messenger IP/Computer name 1 :	<input type="text"/>
Messenger IP/Computer name 2 :	<input type="text"/>
Messenger IP/Computer name 3 :	<input type="text"/>
Send events :	<input type="checkbox"/> INFO <input checked="" type="checkbox"/> WARNING <input checked="" type="checkbox"/> ERROR

System log server	
Server IP/hostname :	<input type="text"/>
UDP Port :	<input type="text" value="514"/>
Facility :	<input type="text" value="User"/>
Event level :	<input type="checkbox"/> INFO <input checked="" type="checkbox"/> WARNING <input checked="" type="checkbox"/> ERROR

Event log filter	
Pop up events :	<input type="checkbox"/> INFO <input type="checkbox"/> WARNING <input type="checkbox"/> ERROR
Show on LCM :	<input type="checkbox"/> INFO <input checked="" type="checkbox"/> WARNING <input checked="" type="checkbox"/> ERROR

“**SNMP**” allows up to 3 SNMP trap addresses. Default community name is set as “public”. User can choose the event log levels and default setting only enables INFO event log in SNMP. There are many SNMP tools. The following web sites are for your reference:

SNMPc: <http://www.snmpc.com/>

Net-SNMP: <http://net-snmp.sourceforge.net/>

Using **"Messenger"**, user must enable the service "Messenger" in Windows (Start → Control Panel → Administrative Tools → Services → Messenger), and then event logs can be received. It allows up to 3 messenger addresses. User can choose the event log levels and default setting enables the WARNING and ERROR event logs.

Using **"System log server"**, user can choose the facility and the event log level. The default port of syslog is 514. The default setting enables event level: INFO, WARNING and ERROR event logs.

Configuration

The following configuration is a sample for target and log server setting:

Target side

1. Go to \System configuration\Notification setting\System log server.
2. Fill the fields
3. Server IP/hostname: enter the IP address or hostname of system log server.
4. UDP Port: enter the UDP port number on which system log server is listening to. The default port number is 514.
5. Facility: select the facility for event log.
6. Event level: Select the event log options.
7. Click "Confirm" button.

Server side (Linux – RHEL4)

The following steps are used to log RAID subsystem messages to a disk file. In the following, all messages are setup with facility "Local1" and event level "WARNING" or higher are logged to /var/log/raid.log.

1. Flush firewall
2. Add the following line to /etc/syslog.conf
Local1.warn /var/log/raid.log
3. Send a HUP signal to syslogd process, this lets syslogd perform a re-initialization. All open files are closed, the configuration file (default is /etc/syslog.conf) will be reread and the syslog(3) facility is started again.
4. Activate the system log daemon and restart
Note: syslogd has a parameter "-r" , which will enable syslogd to receive message from the network using the internet domain socket with the syslog service, this option is introduced in version 1.3 of syslogd package.
5. Check the syslog port number,
e.g. , 10514
6. Change controller's system log server port number as above
Then, syslogd will direct the selected event log messages to /var/log/raid.log when syslogd receive the messages from RAID subsystem.
For more detail features, please check the syslogd and syslog.conf manpage (e.g.,man syslogd).

Server side (Windows 2003)

Windows doesn't provide system log server, user needs to find or purchase a client from third party, below URL provide evaluation version, you may use it for test first. <http://www.winsyslog.com/en/>

1. Install winsyslog.exe
2. Open "Interactives Syslog Server"
3. Check the syslog port number, e.g., 10514
4. Change controller's system log server port number as above
5. Start logging on "Interactives Syslog Server"

There are some syslog server tools. The following web sites are for your reference:

WinSyslog: <http://www.winsyslog.com/>

Kiwi Syslog Daemon: <http://www.kiwisyslog.com/>

Most UNIX systems have built-in syslog daemon.

“Event log filter” setting can enable event level on “Pop up events” and “LCM”.

3.5 iSCSI Configuration

“iSCSI configuration” is designed for setting up the “Entity Property”, “NIC”, “Node”, “Session”, and “CHAP account”.

/ iSCSI configuration	
Entity property	iSCSI entity property
NIC	iSCSI portal configuration
Node	iSCSI node configuration
Session	iSCSI session information
CHAP account	Add/Remove account for iSCSI node

3.5.1 Entity Property

“Entity property” is used to view the entity name of the iSCSI RAID subsystem, and setup “iSNS IP” for iSNS (Internet Storage Name Service). iSNS protocol allows automated discovery, management and configuration of [iSCSI](#) devices on a [TCP/IP](#) network. Using iSNS, it requires that an iSNS server be setup in the SAN. Add an iSNS server IP address into iSNS server lists in order that iSCSI initiator service can send queries.

/ iSCSI configuration / Entity property	
Entity name :	<input type="text" value="iqn.2004-08.com.vendor:iSCSI-Model-000a6d299"/>
iSNS IP :	<input type="text"/>

3.5.2 NIC

“NIC” function is used to change the IP addresses of iSCSI data ports. The iSCSI RAID subsystem has four gigabit LAN ports to transmit data. Each of them must be assigned to one IP address in multi-homed mode unless the link aggregation or trunking mode has been selected. If any two or more ports are set in link aggregation or trunking mode, they will display the same IP.

Name	LAG	LAG No	DHCP	IP address	Netmask	Gateway	Jumbo frame	MAC address	Link
LAN1	No	N/A	No	192.168.11.226	255.255.255.0	192.168.11.254	Disabled	00:13:78:a6:06:18	Up
LAN2	No	N/A	No	192.168.12.226	255.255.255.0	192.168.12.254	Disabled	00:13:78:a6:06:19	Up
LAN3	No	N/A	No	192.168.13.226	255.255.255.0	192.168.13.254	Enabled	00:13:78:a6:06:1a	Up
LAN4	No	N/A	No	192.168.14.226	255.255.255.0	192.168.14.254	Disabled	00:13:78:a6:06:1b	Up

IP settings for iSCSI ports

Become default gateway

Enable jumbo frame

Aggregation ●

IP settings:

User can change IP address by moving mouse to the gray button of LAN port, click “**IP settings for iSCSI ports**”. There are 2 selections, DHCP (Get IP address from DHCP server) or static IP.

DHCP

Static

Address :

Mask :

Gateway :

Default gateway:

Default gateway can be changed by moving mouse to the gray button of LAN port, click “**Become default gateway**”. There is only one default gateway.

MTU / Jumbo frame:

MTU (Maximum Transmission Unit) size can be enabled by moving mouse to the gray button of LAN port, click “**Enable jumbo frame**”.



WARNING! The MTU size of network switch and HBA on host must be enabled. Otherwise, the LAN connection will not work properly.

Multi-homed / Trunking / LACP:

The following is the description of multi-homed/trunking/LACP.

1. **Multi-homed:** Default mode. Each of iSCSI data port is connected by itself and is not set to link aggregation and trunking. Selecting this mode can also remove the setting of Trunking/LACP at the same time.
2. **Trunking:** defines the use of multiple iSCSI data ports in parallel to increase the link speed beyond the limits of any single port.
3. **LACP:** The Link Aggregation Control Protocol (LACP) is part of IEEE specification 802.3ad that allows bundling several physical ports together to form a single logical channel. LACP allows a network switch to negotiate an automatic bundle by sending LACP packets to the peer. The advantages of LACP are: (1) increase in bandwidth, and (2) failover when link status fails on a port.

Trunking/LACP setting can be changed by clicking the button “  ”.

Aggregation : Trunking LACP

Address :

Mask :

Gateway :

NIC : LAN1 LAN2 LAN3 LAN4

There are 4 iSCSI data ports. Select at least two NICs for link aggregation.

Name	LAG	LAG No	DHCP	IP address	Netmask	Gateway	Jumbo frame	MAC address	Link
LAN1	Trunking	0	No	192.168.1.1	255.255.255.0	192.168.1.254	Disabled	00:13:78:a6:06:18	Up
LAN2	Trunking	0	No	192.168.1.1	255.255.255.0	192.168.1.254	Disabled	00:13:78:a6:06:18	Up
LAN3	LACP	1	No	192.168.3.1	255.255.255.0	192.168.3.254	Disabled	00:13:78:a6:06:1a	Up
LAN4	LACP	1	No	192.168.3.1	255.255.255.0	192.168.3.254	Disabled	00:13:78:a6:06:1a	Up

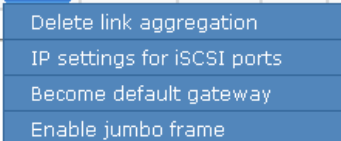



For example, LAN1 and LAN2 are set to Trunking mode. LAN3 and LAN4 are set to LACP mode. To remove Trunking/LACP setting, mouse move to the gray button of LAN port, click “**Delete link aggregation**”. Then it will pop up a message to confirm.

3.5.3 Node

“Node” can be used to view the target name for iSCSI initiator.

This iSCSI RAID model supports multi-node. There is no default node name, i.e. it is empty. It must be created first, and then the iSCSI RAID system can be used. When using “Quick install”, a node name like “iqn.1997-05.com.vendor:iSCSI-Model-xxxxxxx:target0” will be created automatically.

Auth	Name	Portal
None	all	192.168.11.226:3260, 192.168.12.226:3260, 192.168.13.226:3260, 192.168.14.226:3260
None	iqn.1997-05.com.vendor:iSCSI-Model-000a200ed:target0	192.168.11.226:3260, 192.168.12.226:3260, 192.168.13.226:3260, 192.168.14.226:3260
None	1112	192.168.11.226:3260, 192.168.12.226:3260
None	1314	192.168.13.226:3260, 192.168.14.226:3260

Authenticate
Rename
User
Delete

Create

Click “Create” to create a node name.

Name :

Authentication : None

Portal :

- 192.168.11.226:3260 (LAN 1, DHCP: No, Jumbo frame: Disabled)
- 192.168.12.226:3260 (LAN 2, DHCP: No, Jumbo frame: Disabled)
- 192.168.13.226:3260 (LAN 3, DHCP: No, Jumbo frame: Enabled)
- 192.168.14.226:3260 (LAN 4, DHCP: No, Jumbo frame: Disabled)

CHAP:

CHAP is the abbreviation of **C**hallenge **H**andshake **A**uthorization **P**rotocol. CHAP is a strong authentication method used in point-to-point for user login. It’s a type of authentication in which the authentication server sends the client a key to be used for encrypting the username and password. CHAP enables the username and password to transmitting in an encrypted form for protection.

To use CHAP authentication, please follow these steps:

1. Move the mouse pointer to the gray button of “Auth” column, click “Authenticate”.
2. Select “CHAP”.

Authentication : None

None
CHAP

3. Click " ".

Auth	Name	Portal
CHAP <input type="button" value="•"/>	all	192.168.11.226:3260, 192.168.12.226:3260, 192.168.13.226:3260, 192.168.14.226:3260
None <input type="button" value="•"/>	iqn.1997-05.com.vendor.iSCSI-Model-000a200ed:target0	192.168.11.226:3260, 192.168.12.226:3260, 192.168.13.226:3260, 192.168.14.226:3260
None <input type="button" value="•"/>	1112	192.168.11.226:3260, 192.168.12.226:3260
None <input type="button" value="•"/>	1314	192.168.13.226:3260, 192.168.14.226:3260

4. Go to “/ iSCSI configuration / CHAP account” page to create CHAP account. Please refer to next section for more detail.
5. Move the mouse pointer to the gray button of “Auth” column, click “User”.
6. Select CHAP user(s) which will be used. It’s a multiple option selection; it can be one or more. If none is chosen, CHAP can not work.

Node : all

<input checked="" type="checkbox"/>	User
<input checked="" type="checkbox"/>	chap1
<input checked="" type="checkbox"/>	chap2

7. Click " ".

8. In “Change Authenticate” page, select “None” to disable CHAP.



NOTE: After setting CHAP, the initiator in host/server should be set the same CHAP account. Otherwise, user cannot login.

3.5.4 Session

“**Session**” can display iSCSI session and connection information, including the following items:

1. Host (Initiator Name)
2. Error Recovery Level
3. Error Recovery Count
4. Detail of Authentication status and Source IP: port number.

No.	Initiator name	TPGT	Error recovery level	Error recovery count
0	qa-tim-svr1	0x00	0	0

List connection

Delete

Move the mouse pointer to the gray button of session number, click “**List connection**”. It will list all connection(s) of the session.

No.	Initiator IP	Initiator name	Authentication
1	192.168.11.201	qa-tim-svr1	No

3.5.5 CHAP Account

“CHAP account” is used to manage CHAP accounts for authentication. This iSCSI RAID subsystem allows creation of many CHAP accounts.

To setup CHAP account, please follow these steps:

1. Click “ ”.
2. Enter “**User**”, “**Secret**”, and “**Confirm**” secret again. “**Node**” can be selected here or later. If selecting none, it can be enabled in “/ iSCSI configuration / Node / User”.

User : (max: 223)

Secret : (min: 12, max: 16)

Confirm : (min: 12, max: 16)

Node :
iqn.2007-05.com.vendor:iSCSI-Model-000a200ed:target0
1112
1314

3. Click “ ”.

User	Node name
chap1	
chap2	iqn.2007-05.com.vendor:iSCSI-Model-000a200ed:target0

In this example, two CHAP accounts “chap1” and “chap2” have been created. “chap2” is enabled in node name “iqn.2007-05.com.vendor:iSCSI-Model-000a200ed:target0”.

4. Click “**Delete**” to delete a CHAP account.

3.6 Volume Configuration

“Volume configuration” is designed for setting up the volume configuration which includes “Volume create wizard”, “Physical disk”, “RAID group”, “Virtual disk”, “Snapshot”, and “Logical unit”.

/ Volume configuration	
Volume creation wizard	Easy and quick step-by-step volume configuration
Physical disk	Hard disks to store data
RAID group	Sets of physical disks with RAID functions
Virtual disk	Slices of RAID groups
Snapshot	Point-in-time copies of the data
Logical unit	Target volumes for hosts access

3.6.1 Volume Create Wizard

“Volume create wizard” has smart policy. When the system is inserted with several HDDs, “Volume create wizard” will list all possibilities and sizes in different RAID levels. It will use all available HDDs for RAID level depending on which user chooses. When system has different sizes of HDDs, e.g., 8*200G and 8*80G, it lists all possibilities and combination in different RAID level and different sizes. After user selects the RAID level, user may find that some HDDs are available (free status). This is the result of smart policy designed in the iSCSI RAID subsystem. It gives user:

1. Biggest capacity of RAID level for user to choose, and
2. The fewest disk number for RAID level / volume size.

E.g., user chooses RAID 5 and the controller has 12*200G + 4*80G HDDs inserted. If we use all 16 HDDs for a RAID 5, and then the maximum size of volume is 1200G (80G*15). With the wizard, it will do smarter check and find out the most efficient way of using the HDDs. The wizard will only use 200G HDDs (Volume size is 200G*11=2200G), the volume size is bigger and fully uses HDD capacity.

Step 1: Select “Volume create wizard” and then choose the RAID level. After the RAID level is chosen, click “  ”. Then it will link to next page.

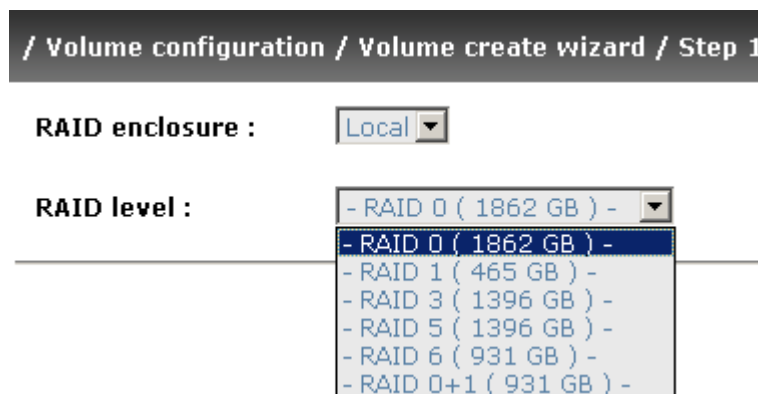

Step 2: Please select the combination of the RG capacity, or **“Use default algorithm”** for maximum RG capacity. After RG size is chosen, click “ ”.

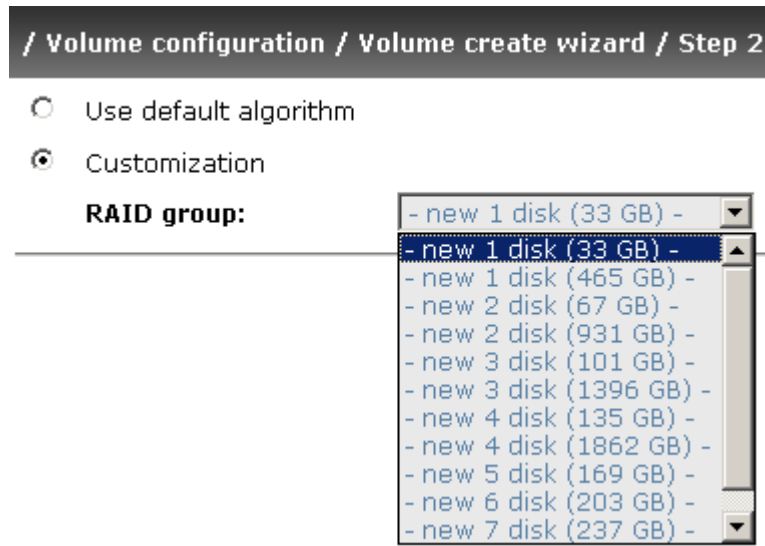

Step 3: Decide VD size. User can enter a number less or equal to the default number. Then click “ ”.



Step 4: Confirm page. Click “ ” if all setups are correct. Then a VD will be created.

Done. You can start to use the system now.

No.	Name	Size (GB)	Right	Priority	Bg rate	Status	Health	R %	RAID	#LUN	Snapshot (MB)	#Snapshot	RG name
1	QUICK14274	1862	WB	HI	4	Online	Optimal		RAID 0	1	0/0	0	QUICK13573

A RAID 0 Virtual disk with the VD name “QUICK13573”, named by the system itself, with the total available volume size of 1862GB.

3.6.2 Physical Disk

“Physical disk” can be used to view the status of hard drives in the system. The following are operational tips:

1. Move the mouse pointer to the gray button next to the PD slot number; it will show the functions which can be executed.
2. Active function can be selected, but inactive function will show in gray color.

For example, set PD slot number 4 to dedicated spare disk.

Step 1: Move the mouse pointer to the gray button of PD 4, select “Set Dedicated spare”, it will link to next page.

4	465		Online	Good	FR	Seagate	3PM0FRH7	SATA2	Enabled	Disabled
<div style="background-color: #4a7c9c; color: white; padding: 2px;">Set Free disk</div> <div style="background-color: #4a7c9c; color: white; padding: 2px;">Set Global spare</div> <div style="background-color: #4a7c9c; color: white; padding: 2px;">▶ Set Dedicated spare</div> <div style="background-color: #4a7c9c; color: white; padding: 2px;">Set property</div> <div style="background-color: #4a7c9c; color: white; padding: 2px;">More information</div>			Online	Good	FR	HITACHI	J3XADKPJ	SAS	Enabled	Disabled
			Online	Good	FR	HITACHI	J3XAB71J	SAS	Enabled	Disabled
			Online	Good	FR	HITACHI	J3XAE5MJ	SAS	Enabled	Disabled
8	33		Online	Good	FR	HITACHI	J3XAAYRJ	SAS	Enabled	Disabled

Step 2: Maybe there are some existing RGs which can be assigned dedicate spare disk. Select which RG will be assigned, then click “”.

Available VG for slot 4 on Local :

	No.	Name	Total (GB)	Free (GB)	#PD	#VD	Status	Health	RAID	Enclosure
⊙	1	RG-R5	931	931	3	0	Online	Good	RAID 5	Local

Done. View “Physical disk” page.

Local

Slot	Size (GB)	RG name	Status	Health	Usage	Vendor	Serial	Type	Write cache	Standby
1	465	RG-R5	Online	Good	RD	Maxtor	H80DMBPH	SATA2	Enabled	Disabled
2	465	RG-R5	Online	Good	RD	Maxtor	H81173QH	SATA2	Enabled	Disabled
3	465	RG-R5	Online	Good	RD	Seagate	3PM0H4C0	SATA2	Enabled	Disabled
4	465	RG-R5	Online	Good	DS	Seagate	3PM0FRH7	SATA2	Enabled	Disabled
5	33		Online	Good	FR	HITACHI	J3XADKPJ	SAS	Enabled	Disabled
6	33		Online	Good	FR	HITACHI	J3XAB71J	SAS	Enabled	Disabled
7	33		Online	Good	FR	HITACHI	J3XAE5MJ	SAS	Enabled	Disabled
8	33		Online	Good	FR	HITACHI	J3XAAYRJ	SAS	Enabled	Disabled

Physical disks of slot 1, 2, and 3 are RAID members (RD) of RG named "RG-R5". Slot 4 is set as dedicated spare disk (DS). The others are free disks (FR).

- **PD column description:**

Slot	The position of hard drives. The button next to the number of slot shows the functions which can be executed.
Size (GB)	Capacity of hard drive.
RG Name	Related RAID group name.
Status	The status of hard drive. "Online" → the hard drive is online. "Rebuilding" → the hard drive is being rebuilt. "Transition" → the hard drive is being migrated or is replaced by another disk when rebuilding occurs. "Missing" → the hard drive has already joined a RG but not plugged into the disk tray of current system.
Health	The health of hard drive. "Good" → the hard drive is good. "Failed" → the hard drive is failed. "Error Alert" → S.M.A.R.T. error alert. "Read Errors" → the hard drive has unrecoverable read errors.
Usage	"RD" → RAID Disk. This hard drive has been set to RAID. "FR" → FRee disk. This hard drive is free for use.

	<p>"DS" → Dedicated Spare. This hard drive has been set to the dedicated spare of the RG.</p> <p>"GS" → Global Spare. This hard drive has been set to a global spare of all RGs.</p> <p>"RS" → ReServe. The hard drive contains the RG information but cannot be used. It may be caused by an uncompleted RG set, or hot-plug of this disk in the running time. In order to protect the data in the disk, the status changes to reserve. It can be reused after setting it to "FR" manually.</p>
Vendor	Hard drive vendor.
Serial	Hard drive serial number.
Type	<p>Hard drive type.</p> <p>"SATA" → SATA disk.</p> <p>"SATA2" → SATA II disk.</p> <p>"SAS" → SAS disk.</p>
Write cache	Hard drive write cache is enabled or disabled.
Standby	HDD auto spindown function to save power. The default value is disabled.

- **PD operations description:**

Set Free disk	Make the selected hard drive to be free for use.
Set Global spare	Set the selected hard drive to global spare of all RGs.
Set Dedicated spares	Set hard drive to dedicated spare of selected RGs.
Set property	<p>Change the status of write cache and standby.</p> <p>Write cache options:</p> <p>"Enabled" → Enable disk write cache.</p> <p>"Disabled" → Disable disk write cache.</p> <p>Standby options:</p> <p>"Disabled" → Disable spindown.</p> <p>"30 sec / 1 min / 5 min / 30 min" → Enable hard drive auto spindown to save power in the period of time.</p>
More information	Show hard drive detail information.

3.6.3 RAID Group

“RAID group” is used to create RAID group or view the status of each RAID group. The following is an example to create a RG.

Step 1: Click “”, enter “Name”, choose “RAID level”, click “” to select PD. Then click “”.

Name :

RAID level :

RAID PD slot :

Write Cache :

Standby :
Disabled
30 sec
1 min
5 min
30 min

Step 2: Confirm page. Click “” if all setups are correct.

No.	Name	Total (GB)	Free (GB)	#PD	#VD	Status	Health	RAID	Enclosure
1	RG-R0	135	135	4	0	Online	Good	RAID 0	Local
2	RG-R5	931	931	3	0	Online	Good	RAID 5	Local

There are two RGs. One RG, named “RG-R0” with 4 physical disks, is RAID 0 and has total size of 135GB. Another RG is “RG-R5”, a RAID 5 RG with 3 physical disks.

Done. View “RAID group” page.

- **RG column description:**

No.	Number of RAID group. The button next to the No. shows the functions which can be executed.
Name	RAID group name.
Total(GB)	Total capacity of this RAID group.
Free(GB)	Free capacity of this RAID group.
#PD	The number of physical disks in RAID group.
#VD	The number of virtual disks in RAID group.
Status	The status of RAID group. "Online" → the RAID group is online. "Offline" → the RAID group is offline. "Rebuild" → the RAID group is being rebuilt. "Migrate" → the RAID group is being migrated. "Scrub" → the RAID group is being scrubbed.
Health	The health of RAID group. "Good" → the RAID group is good. "Failed" → the hard drive is failed. "Degraded" → the RAID group is not completed. The reason could be lack of one disk or disk failure.
RAID	The RAID level of the RAID group.
Enclosure	RG locates on local or JBOD enclosure.

- **RG operations description:**

Create	Create a RAID group.
Migrate	Migrate a RAID group. Please refer to next chapter for more detail.
Activate	Activate a RAID group; it can be executed when RG status is offline. This is for online roaming purpose.
Deactivate	Deactivate a RAID group; it can be executed when RG status is online. This is for online roaming purpose.
Scrub	Scrub a RAID group. It does parity regeneration. It is supported in RAID 3 / 5 / 6 / 30 / 50 / 60 only.

Delete	Delete a RAID group.
Set disk property	Change the disk status of write cache and standby. Write Cache options: “Enabled” → Enable disk write cache. “Disabled” → Disable disk write cache. Standby options: “Disabled” → Disable spindown. “30 sec / 1 min / 5 min / 30 min” → Enable hard drive auto spindown to save power in the period of time.
More information	Show RAID group detail information.

3.6.4 Virtual Disk

“Virtual disk” can be used to create or view the status of each Virtual disk. The following is an example to create a VD.

Step 1: Click “”, enter “Name”, choose “RG name”, “Stripe height (KB)”, “Block size (B)”, “Read/Write” mode, “Priority”, “Bg rate” (Background task priority), change “Capacity (GB)” if necessary. Then click “”.

/ Volume configuration / Virtual disk / Create

Name :

RG name :

Capacity (GB) :

Stripe height (KB) :

Block size (B) :

Read/Write : Write-through cache Write-back cache

Priority : High priority Middle priority Low priority

Bg rate :

Step 2: Confirm page. Click “ ” if all setups are correct.

No.	Name	Size (GB)	Right	Priority	Bg rate	Status	Health	R %	RAID	#LUN	Snapshot (MB)	#Snapshot	RG name
1	VD-01	30	WB	HI	4	Online	Optimal		RAID 0	0	0/0	0	RG-R0
2	VD-02	20	WB	HI	4	Initiating	Optimal	12	RAID 5	0	0/0	0	RG-R5

- Extend
- Scrub
- Delete
- Set property
- Attach LUN
- Detach LUN
- List LUN
- Set snapshot space
- Cleanup snapshot
- Take snapshot
- Auto snapshot
- List snapshot
- More information

A VD named “VD-01” has been created from RG “RG-R0” and with VD size of 30GB. The other VD is named “VD-02” and is initializing (12%).

Done. View “Virtual disk” page.

- **VD column description:**

No.	Number of this Virtual disk. The button next to the VD No. shows the functions which can be executed.
Name	Virtual disk name.
Size(GB)	Total capacity of the Virtual disk.
Right	<p>“WT” → Write Through.</p> <p>“WB” → Write Back.</p> <p>“RO” → Read Only.</p>
Priority	<p>“HI” → High priority.</p> <p>“MD” → Mid priority.</p> <p>“LO” → Low priority.</p>
Bg rate	<p>Background task priority.</p> <p>“4 / 3 / 2 / 1 / 0” → Default value is 4. The higher number the background priority of a VD has, the more background I/O will be scheduled to execute.</p>

Status	<p>The status of Virtual disk.</p> <p>"Online" → the Virtual disk is online.</p> <p>"Offline" → the Virtual disk is offline.</p> <p>"Initiating" → the Virtual disk is being initialized.</p> <p>"Rebuild" → the Virtual disk is being rebuilt.</p> <p>"Migrate" → the Virtual disk is being migrated.</p> <p>"Rollback" → the Virtual disk is being rolled back.</p> <p>"Scrub" → the Virtual disk is being scrubbed.</p>
Health	<p>The health of Virtual disk.</p> <p>"Optimal" → the Virtual disk is operating and has experienced no failures of the disks that comprise the RG.</p> <p>"Degraded" → At least one disk which comprises space of the Virtual disk has been marked as failed or has been plugged.</p> <p>"Missing" → the Virtual disk has been marked as missing by the system.</p> <p>"Failed" → the Virtual disk has experienced enough failures of the disks that comprise the VD for unrecoverable data loss to occur.</p> <p>"Partial optimal" → the Virtual disk has experienced disk failures.</p>
R %	Ratio of initializing or rebuilding.
RAID	The levels of RAID that Virtual disk is using.
#LUN	Number of LUN(s) that Virtual disk is attaching.
Snapshot (MB)	The Virtual disk size that used for snapshot. The number means "Used snapshot space" / "Total snapshot space" . The unit is in megabytes (MB).
#Snapshot	Number of snapshot(s) that Virtual disk is taken.
RG name	The Virtual disk is related to the RG name

- **VD operations description:**

Extend	Extend a Virtual disk capacity.
Scrub	Scrub a Virtual disk. It's a parity regeneration. It supports RAID 3 / 5 / 6 / 30 / 50 / 60 only.
Delete	Delete a Virtual disk.
Set property	<p>Change the VD name, Right, Priority and Bg rate.</p> <p>Right options:</p> <p> "WT" → Write Through.</p> <p> "WB" → Write Back.</p> <p> "RO" → Read Only.</p> <p>Priority options:</p> <p> "HI" → HIGH priority.</p> <p> "MD" → MiD priority.</p> <p> "LO" → LOW priority.</p> <p>Bg rate options:</p> <p> "4 / 3 / 2 / 1 / 0" → Default value is 4. The higher number the background priority of a VD has, the more background I/O will be scheduled to execute.</p>
Attach LUN	Attach to a LUN.
Detach LUN	Detach to a LUN.
List LUN	List attached LUN(s).
Set snapshot space	Set snapshot space for executing snapshot. Please refer to next chapter for more detail.
Cleanup snapshot	Clean all snapshot VD related to the Virtual disk and release snapshot space.
Take snapshot	Take a snapshot on the Virtual disk.
Auto snapshot	Set auto snapshot on the Virtual disk.
List snapshot	List all snapshot VD related to the Virtual disk.
More information	Show Virtual disk detail information.

3.6.5 Snapshot

“**Snapshot**” can view the status of snapshot. Please refer to next chapter for more detail about snapshot concept. The following is an example to take a snapshot.

Step 1: Create snapshot space. In “/ **Volume configuration / Virtual disk**”, move the mouse pointer to the gray button next to the VD number; click “**Set snapshot space**”.

Step 2: Set snapshot space. Then click “”. The snapshot space is created.

/ Volume configuration / Virtual disk / Set snapshot space

Size : (GB) **Maximun: 105 (GB)**
Free : 105 (GB)

No.	Name	Size (GB)	Right	Priority	Bg rate	Status	Health	R %	RAID	#LUN	Snapshot (MB)	#Snapshot	RG name
1	VD-01	30	WB	HI	4	Online	Optimal		RAID 0	0	263/15360	0	RG-R0
2	VD-02	20	WB	HI	4	Online	Optimal		RAID 5	0	0/0	0	RG-R5

“VD-01” snapshot space has been created, snapshot space is 15360MB, and used 263MB for saving snapshot index.

Step 3: Take a snapshot. In “/ **Volume configuration / Snapshot**”, click “”. It will link to next page. Enter a snapshot name.

Linked snapshot for VD:

No.	Name	Used (MB)	Exported	Right	#LUN	Created time
1	SnapVD-01	0	No	N/A	N/A	Wed May 28 15:22:50 2008

Step 4: Export the snapshot VD. Move the mouse pointer to the gray button next to the Snapshot VD number; click “**Export**”. Enter a capacity for snapshot VD. If size is zero, the exported snapshot VD will be read only. Otherwise, the exported snapshot VD can be read/written, and the size will be the maximum capacity to read/write.

/ Volume configuration / Snapshot / Set quota

Size :
Available : 14 (GB)

Linked snapshot for VD: - VD-01 -

No.	Name	Used (MB)	Exported	Right	#LUN	Created time
1	SnapVD-01	0	Yes	RO	0	Wed May 28 15:22:50 2008
2	SnapVD-02	0	Yes	RW	0	Wed May 28 15:26:40 2008

- Unexport
- Rollback
- Delete
- Attach
- Detach
- List LUN

<< Back Cleanup Auto snapshot Take snapshot

This is the list of snapshots in "VD-01". There are two snapshots in "VD-01". Snapshot VD "SnapVD-01" is exported as read only, "SnapVD-02" is exported as read/write.

Step 5: Attach a LUN for snapshot VD. Please refer to the next section for attaching a LUN.

Done. Snapshot VD can be used.

- **Snapshot column description:**

No.	Number of this snapshot VD. The button next to the snapshot VD No. shows the functions which can be executed.
Name	Snapshot VD name.
Used (MB)	The amount of snapshot space that has been used.
Exported	Snapshot VD is exported or not.
Right	"RW" → Read / Write. The snapshot VD can be read / write. "RO" → Read Only. The snapshot VD can be read only.
#LUN	Number of LUN(s) that snapshot VD is attaching.
Created time	Snapshot VD created time.

- **Snapshot operations description:**

Export / Unexport	Export / unexport the snapshot VD.
Rollback	Rollback the snapshot VD to the original.
Delete	Delete the snapshot VD.
Attach	Attach to a LUN.
Detach	Detach to a LUN.
List LUN	List attached LUN(s).

3.6.6 Logical Unit

“**Logical unit**” can be used to view the status of attached logical unit number of each VD, or can be used to attach or detach a LUN.

User can attach LUN by clicking the “ ”. In the “**Host**” field, user must enter an iSCSI node name for access control, or fill-in wildcard “*”, which means every host can access the volume. Choose LUN number and permission, then click “ ”.

VD :

Host (iSCSI node name) :

Target (iSCSI node name) :

LUN :

Permission : Read-only Read-write

Host	Target	LUN	Permission	VD name	#Session
*	iqn.2007-05.com.vendor:iSCSI-Model-000a200ed:target0	0	Read write	VD-01	0
iqn.1991-05.com.microsoft:demo	all	1	Read write	VD-02	0

Detach

VD-01 is attached to LUN 0 and every host can access. VD-02 is attached to LUN 1 and only initiator node which is named "iqn.1991-05.com.microsoft:demo" can access.

- **LUN operations description:**

Attach	Attach a logical unit number to a Virtual disk.
Detach	Detach a logical unit number from a Virtual disk.

The matching rules of access control are inspected from top to bottom in sequence. For example: there are 2 rules for the same VD, one is "*", LUN 0; and the other is "iqn.host1", LUN 1. The other host "iqn.host2" can login successfully because it matches rule 1.

The access will be denied when there is no matching rule.

3.6.7 Example

The following is an example for creating volumes. Example 1 is to create two VDs and set a global spare disk.

- **Example 1**

Example 1 is to create two VDs in one RG, each VD uses global cache volume. Global cache volume is created after system boots up automatically. So, no action is needed to set CV. Then set a global spare disk. Eventually, delete all of them.

Step 1: Create RG (RAID group).

To create the RAID group, please follow these steps:

1. Select **"/ Volume configuration / RAID group"**.
2. Click **"Create"**.
3. Input an RG Name, choose a RAID level from the list, click **"Select PD"** to choose the RAID PD slot(s), then click **"Next >>"**.



The screenshot shows a configuration form for a RAID group. The fields are: Name: RG-R5; RAID level: RAID 5; RAID PD slot: 1 2 3; Write Cache: Enabled; Standby: Disabled. At the bottom, there are navigation buttons: << Back, Next >>, and Confirm.

4. Check the outcome. Click **"Confirm"** if all setups are correct.
5. Done. An RG has been created.

No.	Name	Total (GB)	Free (GB)	#PD	#VD	Status	Health	RAID	Enclosure
1	RG-R5	931	931	3	0	Online	Good	RAID 5	Local

A RAID 5 RG named "RG-R5" with 3 physical disks is created. The total size is 931GB. Because there is no related VD, free size still remains 931GB.

Step 2: Create VD (Virtual disk).

To create a data user volume, please follow these steps.

1. Select **"/ Volume configuration / Virtual disk"**.
2. Click **"Create"**.

- Input a VD name, choose the RG when VD will be created, enter the VD capacity, select the stripe height, block size, read/write mode and set priority, and finally click "Confirm".

Name :
 RG name :
 Capacity (GB) :
 Stripe height (KB) :
 Block size (B) :
 Read/Write : Write-through cache Write-back cache
 Priority : High priority Middle priority Low priority
 Bg rate :

- Done. A VD has been created.
- Repeat steps 1 to 4 to create another VD.

No.	Name	Size (GB)	Right	Priority	Bg rate	Status	Health	R %	RAID	#LUN	Snapshot (MB)	#Snapshot	RG name
1	VD-R5-1	50	WB	HI	4	Initiating	Optimal	86	RAID 5	1	0/0	0	RG-R5
2	VD-R5-2	64	WB	HI	4	Initiating	Optimal	0	RAID 5	1	0/0	0	RG-R5

Two VDs, "VD-R5-1" and "VD-R5-2", were created from RG "RG-R5". The size of "VD-R5-1" is 50GB, and the size of "VD-R5-2" is 64GB. "VD-R5-1" is initializing about 86%. There is no LUN attached.

Step 3: Attach LUN to VD.

There are 2 methods to attach LUN to VD.

- In "/ Volume configuration / Virtual disk", move the mouse pointer to the gray button next to the VD number; click "Attach LUN".
- In "/ Volume configuration / Logical unit", click "Attach".

The steps are as follows:

VD :
 Host (iSCSI node name) :
 Target (iSCSI node name) :
 LUN :
 Permission : Read-only Read-write

1. Select a VD.
2. Input "Host" name, which is a FC node name for access control, or fill-in wildcard "*", which means every host can access to this volume. Choose LUN and permission, then click "Confirm".
3. Done.

Host	Target	LUN	Permission	VD name	#Session
*	all	0	Read write	VD-R5-1	0
iqn.1991-01.com.microsoft:demo	iqn.2007-05.com.vendor:iSCSI-Model-000a200ed:target0	1	Read write	VD-R5-2	0

VD-R5-1 is attached to LUN 0. VD-R5-2 is attached LUN 1.



NOTE: The matching rules of access control are from top to bottom in sequence.

Step 4: Set global spare disk.

To set global spare disks, please follow the procedures.

1. Select "/ Volume configuration / Physical disk".
2. Move the mouse pointer to the gray button next to the PD slot; click "Set Global space".
3. "GS" icon is shown in "Usage" column.

Slot	Size (GB)	RG name	Status	Health	Usage	Vendor	Serial	Type	Write cache	Standby
1	465	RG-R5	Online	Good	RD	Maxtor	H80DMBPH	SATA2	Enabled	Disabled
2	465	RG-R5	Online	Good	RD	Maxtor	H81173QH	SATA2	Enabled	Disabled
3	465	RG-R5	Online	Good	RD	Seagate	3PM0H4C0	SATA2	Enabled	Disabled
4	465		Online	Good	GS	Seagate	3PM0FRH7	SATA2	Enabled	Disabled
5	33		Online	Good	FR	HITACHI	J3XADKPJ	SAS	Enabled	Disabled
6	33		Online	Good	FR	HITACHI	J3XAB71J	SAS	Enabled	Disabled
7	33		Online	Good	FR	HITACHI	J3XAE5MJ	SAS	Enabled	Disabled
8	33		Online	Good	FR	HITACHI	J3XAAYRJ	SAS	Enabled	Disabled

Slot 4 is set as global spare disk (GS).

Step 5: Done. LUNs can be used as disks.

To delete VDs, RG, please follow the steps listed below.

Step 6: Detach LUN from VD.

In “/ **Volume configuration / Logical unit**”,

1. Move the mouse pointer to the gray button next to the LUN; click “**Detach**”. There will pop up a confirmation page.

Host	Target	LUN	Permission	VD name	#Session
*	all	0	Read write	VD-R5-1	0
ig 01.com.microsoft:demo	iqn:2007-05.com.vendor:iscsi-Model-000a200ed:target0	1	Read write	VD-R5-2	0

2. Choose “OK”.
3. Done.

Step 7: Delete VD (Virtual disk).

To delete the Virtual disk, please follow the procedures:

1. Select “/ **Volume configuration / Virtual disk**”.
2. Move the mouse pointer to the gray button next to the VD number; click “**Delete**”. There will pop up a confirmation page, click “**OK**”.
3. Done. Then, the VDs are deleted.



NOTE: When deleting VD, the attached LUN(s) related to this VD will be detached automatically.

Step 8: Delete RG (RAID group).

To delete the RAID group, please follow the procedures:

1. Select “/ **Volume configuration / RAID group**”.
2. Select a RG which is no VD related on this RG, otherwise the VD(s) on this RG must be deleted first.
3. Move the mouse pointer to the gray button next to the RG number click “**Delete**”.
4. There will pop up a confirmation page, click “**OK**”.
5. Done. The RG has been deleted.



NOTE: The action of deleting one RG will succeed only when all of the related VD(s) are deleted in this RG. Otherwise, it will have an error when deleting this RG.

Step 9: Free global spare disk.

To free global spare disks, please follow the procedures.

1. Select “/ **Volume configuration / Physical disk**”.
2. Move the mouse pointer to the gray button next to the PD slot; click “**Set Free disk**”.

Step 10: Done, all volumes have been deleted.

3.7 Enclosure Management

“Enclosure management” allows managing enclosure information including “SES configuration”, “Hardware monitor”, “S.M.A.R.T.” and “UPS”. For the enclosure management, there are many sensors for different purposes, such as temperature sensors, voltage sensors, hard disks, fan sensors, power sensors, and LED status. Due to the different hardware characteristics among these sensors, they have different polling intervals. Below are the details of polling time intervals:

1. Temperature sensors: 1 minute.
2. Voltage sensors: 1 minute.
3. Hard disk sensors: 10 minutes.
4. Fan sensors: 10 seconds . When there are 3 errors consecutively, controller sends ERROR event log.
5. Power sensors: 10 seconds, when there are 3 errors consecutively, controller sends ERROR event log.
6. LED status: 10 seconds.

/ Enclosure management	
SES configuration	Access control for SES management
Hardware monitor	System monitored voltage, temperature and battery backup module
S.M.A.R.T.	Self-monitoring analysis and reporting technology for physical disks
UPS	Uninterruptible power supply

3.7.1 SES Configuration

SES represents SCSI Enclosure Services, one of the enclosure management standards. “SES configuration” can enable or disable the management of SES.

Host	Target	LUN
*	iqn.2007-05.com.vendor:iSCSI-Model-000a200ed:target0	0

Disable

The SES client software is available at the following web site:

SANtools: <http://www.santools.com/>

3.7.2 Hardware Monitor

“**Hardware monitor**” can be used to view the information of current voltage, temperature levels, and fan speed.

/ Enclosure management / Hardware monitor	
Local	
Item	Information
+1.2V:	+1.20 V (min = +1.14 V, max = +1.28 V)
+3.3V:	+3.42 V (min = +3.10 V, max = +3.55 V)
+5V:	+5.14 V (min = +4.80 V, max = +5.35 V)
+12V:	+12.08 V (min = +10.80 V, max = +13.20 V)
+1.8V:	+1.84 V (min = +1.71 V, max = +1.93 V)
PSU +5V(R60):	+5.07 V (min = +4.70 V, max = +5.35 V)
PSU +12V(R60):	+11.93 V (min = +10.80 V, max = +13.20 V)
PSU +3.3V(R60):	+3.39 V (min = +3.10 V, max = +3.55 V)
Core Processor:	+43.5 (C) (hyst = +0.0 (C), high = +80.0 (C))
Onboard SAS Device 1:	+49.0 (C) (hyst = +0.0 (C), high = +80.0 (C))
Onboard SAS Device 2:	+39.0 (C) (hyst = +0.0 (C), high = +80.0 (C))
Location 01(R60):	+23.0 (C) (hyst = +0.0 (C), high = +45.0 (C))
Location 02(R60):	+24.0 (C) (hyst = +0.0 (C), high = +45.0 (C))
Location 03(R60):	+24.5 (C) (hyst = +0.0 (C), high = +45.0 (C))
Location 04(R60):	+25.0 (C) (hyst = +0.0 (C), high = +45.0 (C))
Location 05(R60):	+25.0 (C) (hyst = +0.0 (C), high = +45.0 (C))
Location 06(R60):	+25.0 (C) (hyst = +0.0 (C), high = +45.0 (C))
Location 07(R60):	+25.0 (C) (hyst = +0.0 (C), high = +45.0 (C))
Location 08(R60):	+25.0 (C) (hyst = +0.0 (C), high = +45.0 (C))
Location 09(R60):	+25.0 (C) (hyst = +0.0 (C), high = +45.0 (C))
Location 10(R60):	+25.0 (C) (hyst = +0.0 (C), high = +45.0 (C))
Location 11(R60):	+25.0 (C) (hyst = +0.0 (C), high = +45.0 (C))
Location 12(R60):	+25.0 (C) (hyst = +0.0 (C), high = +45.0 (C))
Location 13(R60):	+25.0 (C) (hyst = +0.0 (C), high = +45.0 (C))
Location 14(R60):	+25.0 (C) (hyst = +0.0 (C), high = +45.0 (C))
Location 15(R60):	+24.5 (C) (hyst = +0.0 (C), high = +45.0 (C))
Location 16(R60):	+25.0 (C) (hyst = +0.0 (C), high = +45.0 (C))
PSU1(R60):	good
PSU2(R60):	good
FAN1(R60):	good (5921 RPM)
FAN2(R60):	good (5532 RPM)
FAN3(R60):	good (5921 RPM)
FAN4(R60):	good (5625 RPM)

Auto shutdown :

If “**Auto shutdown**” has been checked, the system will shutdown automatically when voltage or temperature is out of the normal range. For better data protection, please check “**Auto Shutdown**”.

For better protection and avoiding single short period of high temperature triggering auto shutdown, the RAID controller evaluates multiple conditions for triggering auto shutdown. Below are the details of when the Auto shutdown will be triggered.

1. There are 3 sensors placed on controller for temperature checking, they are on core processor, PCI-X bridge, and daughter board. Controller will check each sensor for every 30 seconds. When one of these sensors is over high temperature value continuously for 3 minutes, auto shutdown will be triggered immediately.
2. The core processor temperature limit is 85°C. The PCI-X bridge temperature limit is 80°C. The daughter board temperature limit is 80°C.
3. If the high temperature situation doesn't last for 3 minutes, controller will not do auto shutdown.

3.7.3 Hard Drive S.M.A.R.T. Support

S.M.A.R.T. (Self-Monitoring Analysis and Reporting Technology) is a diagnostic tool for hard drives to deliver warning of drive failures in advance. S.M.A.R.T. provides users chances to take actions before possible drive failure.

S.M.A.R.T. measures many attributes of the hard drive all the time and inspects the properties of hard drives which are close to be out of tolerance. The advanced notice of possible hard drive failure can allow users to back up hard drive or replace the hard drive. This is much better than hard drive crash when it is writing data or rebuilding a failed hard drive.

“**S.M.A.R.T.**” can display S.M.A.R.T. information of hard drives. The number is the current value; the number in parenthesis is the threshold value. The threshold values of hard drive vendors are different; please refer to vendors' specification for details.

S.M.A.R.T. only supports SATA drive. SAS drive does not have. It will show N/A in this web page.

Local

Slot	HDD type	Read error rate	Spin up time	Reallocated sector count	Seek error rate	Spin up retries	Calibration retries	Temperature (C)
1	SATA	59(6)	98(0)	100(36)	87(30)	100(97)	N/A	32
2	SATA	N/A	220(63)	180(63)	253(0)	253(157)	253(223)	37
3	SATA	N/A	227(63)	253(63)	253(0)	253(157)	253(223)	32
4	SATA	100(51)	100(25)	98(11)	100(51)	100(51)	100(0)	29
5	SATA	100(60)	147(24)	100(5)	100(67)	100(60)	N/A	33
6	SATA	100(60)	149(24)	100(5)	100(67)	100(60)	N/A	31
7	SATA	N/A	220(63)	253(63)	253(0)	253(157)	253(223)	36
8	SATA	100(51)	100(25)	100(11)	100(51)	100(51)	100(0)	23
9	SATA	100(60)	140(24)	100(5)	100(67)	100(60)	N/A	33
10	SATA	100(51)	100(25)	100(11)	100(51)	100(51)	84(0)	30
11	SATA	100(51)	100(25)	100(11)	100(51)	100(51)	100(0)	30
12	SATA	57(6)	98(0)	100(36)	80(30)	100(97)	N/A	34
13	SATA	100(51)	100(25)	100(11)	100(51)	100(51)	100(0)	29
14	SATA	61(6)	98(0)	100(36)	82(30)	100(97)	N/A	33
15	SATA	69(6)	98(0)	100(36)	81(30)	100(97)	N/A	34
16	SATA	65(6)	98(0)	100(36)	81(30)	100(97)	N/A	30

3.7.4 UPS

“UPS” is used to set up UPS (Uninterruptible Power Supply).

UPS type :

Shutdown battery level (%) :

Shutdown delay (s) :

Shutdown UPS :

Status :

Battery level : 0%

Currently, the system only supports and communicates with APC (American Power Conversion Corp.) smart UPS. Please review the details from the website: <http://www.apc.com/>.

First, connect the system and APC UPS via RS-232 for communication. Then set up the shutdown values when power is failed. UPS in other companies can work well, but they have no such communication feature.

UPS Type	Select UPS Type. Choose Smart-UPS for APC, None for other vendors or no UPS.
Shutdown Battery Level (%)	When below the setting level, system will shutdown. Setting level to “0” will disable UPS.
Shutdown Delay (s)	If power failure occurred, and system can not return to value setting status, the system will shutdown. Setting delay to “0” will disable the function.
Shutdown UPS	Select ON, when power is gone, UPS will shutdown by itself after the system shutdown successfully. After power comes back, UPS will start working and notify system to boot up. OFF will not.
Status	The status of UPS. “Detecting...” “Running” “Unable to detect UPS” “Communication lost” “UPS reboot in progress” “UPS shutdown in progress” “Batteries failed. Please change them NOW!”
Battery Level (%)	Current percentage of battery level.

3.8 System Maintenance

“Maintenance” allows the operation of system functions which include “System information” to show the system version, “Upgrade” to the latest firmware, “Reset to factory default” to reset all controller configuration values to factory settings, “Import and export” to import and export all controller configuration, “Event log” to view system event log to record critical events, and “Reboot and shutdown” to either reboot or shutdown the system.

/ Maintenance	
System information	System information
Upgrade	Remote upload firmware
Reset to factory default	Reset to factory default
Import and export	Import/export configurations
Event log	System event log to record critical events
Reboot and shutdown	Reboot or shutdown system

3.8.1 System Information

“System information” can display system information (iSCSI model name and firmware version), CPU type, installed system memory, and controller serial number.

```
/ Maintenance / System information
System information
iSCSI-Model 1.0.2 (build 200809191500)
CPU type
XSC3-IOP8134x Family rev 9 (v5l)
Installed system memory
ECC Unbuffered DDR-II 1024MB
Controller serial no.
001378A6D299
```

3.8.2 Upgrade

“Upgrade” is used to upgrade firmware. Please prepare new firmware file named “xxxx.bin” in local hard drive, then click “Browse...” to select the file. Click “Confirm”, it will pop up a message “Upgrade system now? If you want to downgrade to the previous FW later (not recommend), please export your system configuration in advance”, click “Cancel” to export system configuration in advance, then click “OK” to start to upgrade firmware.

Browse the firmware to upgrade :

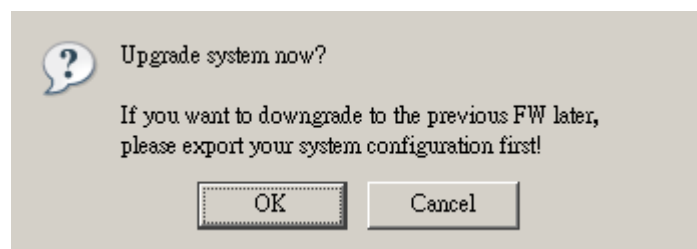

When upgrading, there is a progress bar running. After finished upgrading, the system must reboot manually to make the new firmware took effect.



NOTE: Please contact your vendor for the latest firmware.

3.8.3 Reset to Factory Default

“Reset to factory default” allows user to reset controller to factory default setting.

Sure to reset to factory default?

Reset to default value, the password is: **00000000**, and IP address to default DHCP.

Default IP address: **192.168.10.50** (DHCP)

Default subnet mask: **255.255.255.0**

Default gateway: **192.168.10.254**

3.8.4 Import and Export

“**Import and export**” allows user to save system configuration values: export, and apply all configuration: import. For the volume configuration setting, the values are available in export and not available in import which can avoid conflict/delete-deleting between two controllers. That says if one controller already exists valuable data in the disks and user may forget to overwrite it. Use import could return to original configuration. If the volume setting was also imported, user’s current data will be overwritten.



Import/Export : ▾
Import file :

1. **Import:** Import all system configurations excluding volume configuration.
2. **Export:** Export all configurations to a file.

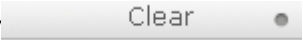

WARNING: “Import” will import all system configurations excluding volume configuration; the current configurations will be replaced.

3.8.5 Event Log

“Event log” can be used to view the event messages. Check the checkbox of INFO, WARNING, and ERROR to choose the level of display event log. Clicking “” button will save the whole event log as a text file with file name “log-ModelName-SerialNumber-Date-Time.txt” (e.g., log-iSCSI-Model-a00001-20080501-120000.txt). Click “” button will clear event log. Click “” button will stop alarm if system alerts.

Show events : INFO WARNING ERROR

Type	Time	Content
INFO	2008/05/28 16:14:46	VD VD-R5-2 starts initialization.
INFO	2008/05/28 16:14:46	VD VD-R5-1 completes the initialization.
INFO	2008/05/28 16:11:45	PD 4 has been configured as a global spare disk.
INFO	2008/05/28 16:07:20	VD VD-R5-2 has been created.
INFO	2008/05/28 16:07:01	VD VD-R5-1 starts initialization.
INFO	2008/05/28 16:07:01	VD VD-R5-1 has been created.
INFO	2008/05/28 16:04:25	RG RG-R5 has been created.
INFO	2008/05/28 16:02:57	RG RG-R5 has been deleted.
INFO	2008/05/28 16:02:53	RG RG-R0 has been deleted.
INFO	2008/05/28 16:02:45	VD VD-02 has been deleted.
INFO	2008/05/28 16:02:41	VD SnapVD-02 has been deleted.
INFO	2008/05/28 16:02:41	VD SnapVD-01 has been deleted.
INFO	2008/05/28 16:02:41	VD VD-01 has been deleted.

The event log is displayed in reverse order which means the latest event log is on the first page. The event logs are actually saved in the first four hard drives; each hard drive has one copy of event log. For one controller, there are four copies of event logs to make sure users can check event log any time when there is/are failed disk(s).



NOTE: Please plug-in any of the first four hard drives, then event logs can be saved and displayed in next system boot up. Otherwise, the event logs would disappear.

3.8.6 Reboot and Shutdown

“Reboot and shutdown” displays “Reboot” and “Shutdown” buttons. Before power off, it’s better to execute “Shutdown” to flush the data from cache to physical disks. The step is necessary for data protection.



3.9 Logout

For security reason, “**Logout**” allows users to logout when user does not need to operate the system. To re-login, enter username and password again.

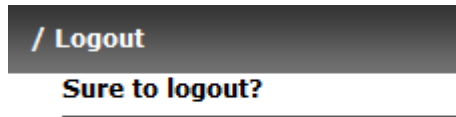

Click “Confirm” to proceed with logout.

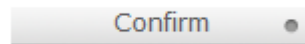

Chapter 4 Advanced Operation

4.1 Rebuild

If one physical disk from a RG, which is set to a protected RAID level (e.g. RAID 3, RAID 5, or RAID 6), failed or has been unplugged/removed, the status of RG is changed to degraded mode. The system will search/detect spare disk to rebuild the degraded RG to become normal/complete. It will detect dedicated spare disk as rebuild disk first, then global spare disk.

The iSCSI RAID subsystem supports Auto-Rebuild. The following is the scenario:

Take RAID 6 for example:

1. When there is no global spare disk or dedicated spare disk in the system, controller will be in degraded mode and wait until (A) there is one disk assigned as spare disk, or (B) the failed disk is removed and replaced with new clean disk, then the Auto-Rebuild starts. The new disk will be a spare disk to the original RG automatically.

If the new added disk is not clean (with other RG information), it would be marked as RS (reserved) and the system will not start "auto-rebuild".

If this disk is not belonging to any existing RG, it would be FR (Free) disk and the system will start Auto-Rebuild.

If user only removes the failed disk and plugs the same failed disk in the same slot again, the auto-rebuild will start running. But rebuilding in the same failed disk may impact customer data if the status of disk is unstable. It is recommended for users not to rebuild in the failed disk for better data protection.

2. When there is enough global spare disk(s) or dedicated spare disk(s) for the degraded array, the system starts Auto-Rebuild immediately. And in RAID 6, if another disk failure occurs during rebuilding, the system will start the above Auto-Rebuild process as well. Auto-Rebuild feature only works when the status of RG is "**Online**". It will not work at "**Offline**" status. Thus, it will not conflict with the "**Roaming**".
3. In degraded mode, the status of RG is "**Degraded**". When rebuilding, the status of RG/VD will be "**Rebuild**", the column "**R%**" in VD will display the ratio in percentage. After completing the rebuilding process, the status will become "Online". RG will become complete or normal.



NOTE: "Set dedicated spare" is not available if there is no RG, or if RG is set to RAID 0 or JBOD, because user can not set dedicated spare disk to RAID 0 & JBOD.

Sometimes, rebuild is called recover; they are the same meaning. The following table is the relationship between RAID levels and rebuild.

RAID 0	Disk striping. No protection for data. RG fails if any hard drive fails or unplugs.
RAID 1	Disk mirroring over 2 disks. RAID 1 allows one hard drive fails or unplugging. Need one new hard drive to insert to the system and rebuild to be completed.
N-way mirror	Extension to RAID 1 level. It has N copies of the disk. N-way mirror allows N-1 hard drives failure or unplugging.
RAID 3	Striping with parity on the dedicated disk. RAID 3 allows one hard drive failure or unplugging.
RAID 5	Striping with interspersed parity over the member disks. RAID 5 allows one hard drive failure or unplugging.
RAID 6	2-dimensional parity protection over the member disks. RAID 6 allows two hard drives failure or unplugging. If it needs to rebuild two hard drives at the same time, it will rebuild the first one, then the other in sequence.
RAID 0+1	Mirroring of RAID 0 volumes. RAID 0+1 allows two hard drive failures or unplugging, but at the same array.
RAID 10	Striping over the member of RAID 1 volumes. RAID 10 allows two hard drive failure or unplugging, but in different arrays.
RAID 30	Striping over the member of RAID 3 volumes. RAID 30 allows two hard drive failure or unplugging, but in different arrays.
RAID 50	Striping over the member of RAID 5 volumes. RAID 50 allows two hard drive failures or unplugging, but in different arrays.
RAID 60	Striping over the member of RAID 6 volumes. RAID 40 allows four hard drive failures or unplugging, every two in different arrays.
JBOD	The abbreviation of "Just a Bunch Of Disks". No data protection. RG fails if any hard drive failures or unplugs.

4.2 RG Migration

To migrate the RAID level, please follow the steps below.

1. Select “/ **Volume configuration / RAID group**”.
2. Move the mouse pointer to the gray button next to the RG number; click “**Migrate**”.
3. Change the RAID level by clicking the down arrow to “**RAID 5**”. There will be a pup-up which indicates that HDD is not enough to support the new setting of RAID level, click “” to increase hard drives, then click “” to go back to setup page. When doing migration to lower RAID level, such as the original RAID level is RAID 6 and user wants to migrate to RAID 0, system will evaluate whether this operation is safe or not, and appear a message of “**Sure to migrate to a lower protection array?**” to give user warning.

Name :

RAID level :

RAID PD slot :

4. Double check the setting of RAID level and RAID PD slot. If there is no problem, click “”.
5. Finally a confirmation page shows the detail of RAID information. If there is no problem, click “” to start migration. System also pops up a message of “**Warning: power lost during migration may cause damage of data!**” to give user warning. When the power is abnormally off during the migration, the data is in high risk.
6. Migration starts and it can be seen from the “**status**” of a RG with “**Migrating**”. In “/ **Volume configuration / Virtual disk**”, it displays a “**Migrating**” in “**Status**” and complete percentage of migration in “**R%**”.

No.	Name	Total (GB)	Free (GB)	#PD	#VD	Status	Health	RAID	Enclosure
1	RG-R0->R5	1396	1386	4	1	Migrating	Good	RAID 5	Local

A RAID 0 with 4 physical disks migrates to RAID 5 with 5 physical disks.

No.	Name	Size (GB)	Right	Priority	Bg rate	Status	Health	R %	RAID	#LUN	Snapshot (MB)	#Snapshot	RG name
1	VD-R0->R5	10	WB	HI	4	Migrating	Optimal	6	RAID 5	0	0/0	0	RG-R0->R5

A RAID 0 migrates to RAID 5; the completed percentage is 14%.

To do migration, the total size of RG must be larger or equal to the original RG. It does not allow expanding the same RAID level with the same hard disks of original RG.

The operation is not allowed when RG is being migrated. System would reject following operations:

1. Add dedicated spare.
2. Remove a dedicated spare.
3. Create a new VD.
4. Delete a VD.
5. Extend a VD.
6. Scrub a VD.
7. Perform yet another migration operation.
8. Scrub entire RG.
9. Take a new snapshot.
10. Delete an existing snapshot.
11. Export a snapshot.
12. Rollback to a snapshot.



IMPORTANT! RG Migration cannot be executed during rebuild or VD extension.

4.3 VD Extension

To extend VD size, please follow the procedures.

1. Select “/ **Volume configuration / Virtual disk**”.
2. Move the mouse pointer to the gray button next to the VD number; click “**Extend**”.
3. Change the size. The size must be larger than the original, and then click “ ” to start extension.

Size :
Free : 1386 (GB)

4. Extension starts. If VD needs initialization, it will display “**Initiating**” in “**Status**” and the completed percentage of initialization in “**R%**” column.

No.	Name	Size (GB)	Right	Priority	Bg rate	Status	Health	R %	RAID	#LUN	Snapshot (MB)	#Snapshot	RG name
1	VD-R0->R5	20	WB	HI	4	Initiating	Optimal	69	RAID 5	0	0/0	0	RG-R0->R5



NOTE: The size of VD extension must be larger than original.



IMPORTANT! VD Extension cannot be executed during rebuild or migration.

4.4 Snapshot / Rollback

Snapshot-on-the-box captures the instant state of data in the target volume in a logical sense. The underlying logic is Copy-on-Write -- moving out the data which would be written to certain location where a write action occurs since the time of data capture. The certain location, named as "Snap VD", is essentially a new VD, which can be attached to a LUN provisioned to a host as a disk like other ordinary VDs in the system. Rollback restores the data back to the state of any time which was previously captured in case for any unfortunate reason it might be (e.g. virus attack, data corruption, human errors and so on). Snap VD is allocated within the same RG in which the snapshot is taken, we suggest to reserve 20% of RG size or more for snapshot space. Please refer to the figure below for the snapshot concept.

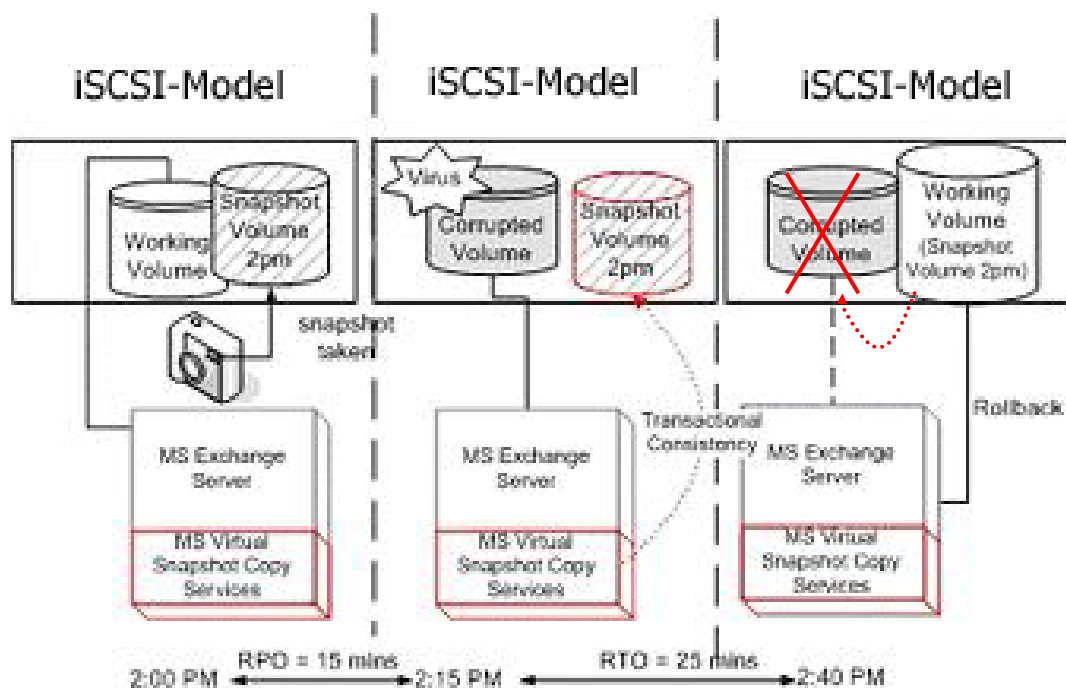

IMPORTANT! Snapshot / rollback features need at least 1 GB controller cache RAM. Please also refer to RAM certification list in Appendix A.

4.4.1 Create Snapshot Volume

To take a snapshot of the data, please follow the procedures.

1. Select “/ **Volume configuration / Virtual disk**”.
2. Move the mouse pointer to the gray button next to the VD number; click “**Set snapshot space**”.
3. Set up the size for snapshot. The minimum size is suggested to be **20%** of VD size, then click “”. It will go back to the VD page and the size will show in snapshot column. It may not be the same as the number entered because some size is reserved for snapshot internal usage. There will be 2 numbers in “**Snapshot (MB)**” column. These numbers are “**Used snapshot space**” and “**Total snapshot space**”.
4. There are two methods to take snapshot. In “/ **Volume configuration / Virtual disk**”, move the mouse pointer to the gray button next to the VD number; click “**Take snapshot**”. Or in “/ **Volume configuration / Snapshot**”, click “”.
5. Enter a snapshot name, then click “”. A snapshot VD is created.
6. Select “/ **Volume configuration / Snapshot**” to display all snapshot VDs related to the VD

Linked snapshot for VD:

No.	Name	Used (MB)	Exported	Right	#LUN	Created time
1	SnapVD-01	0	No	N/A	N/A	Wed May 28 15:22:50 2008

7. Move the mouse pointer to the gray button next to the Snapshot VD number; click “**Export**”. Enter a capacity for snapshot VD. If size is zero, the exported snapshot VD will be read only. Otherwise, the exported snapshot VD can be read/written, and the size will be the maximum capacity to read/write.
8. Attach a LUN for snapshot VD. Please refer to the previous chapter for attaching a LUN.
9. Done. It can be used as a disk.

Linked snapshot for VD: -VD-01 -

No.	Name	Used (MB)	Exported	Right	#LUN	Created time
1	SnapVD-01	0	Yes	RO	0	Wed May 28 15:22:50 2008
2	SnapVD-02	0	Yes	RW	0	Wed May 28 15:26:40 2008

- Unexport
- Rollback
- Delete
- Attach
- Detach
- List LUN

<< Back Cleanup Auto snapshot Take snapshot

10. There are two methods to clean all snapshots. In “/ **Volume configuration / Virtual disk**”, move the mouse pointer to the gray button next to the VD number; click “**Cleanup snapshot**”. Or in “/ **Volume configuration / Snapshot**”, click “ Cleanup ”.
11. Cleanup will delete all snapshots related to the VD and release snapshot space.

Snapshot has some constraints such as the following:

1. Minimum RAM size for enabling snapshot is **1GB**.
2. For performance and future rollback, system saves snapshot with names in sequences. For example, three snapshots has been taken and named “SnapVD-01”(first), “SnapVD-02” and “SnapVD-03”(last). When deleting “SnapVD-02”, both of “SnapVD-02” and “SnapVD-03” will be deleted because “SnapVD-03” is related to “SnapVD-02”.
3. For resource management, maximum number of snapshots in system is **32**.
4. If the snapshot space is full, system will send a warning message of space full and the new taken snapshot will replace the oldest snapshot in rotational sequence by executing auto snapshot, but new snapshot can not be taken by manual because system does not know which snapshot VDs can be deleted.

4.4.2 Auto Snapshot

The snapshot copies can be taken manually or by schedule such as hourly or daily. Please follow the procedures.

1. There are two methods to set auto snapshot. In “/ **Volume configuration / Virtual disk**”, move the mouse pointer to the gray button next to the VD number; click “**Auto snapshot**”. Or in “/ **Volume configuration / Snapshot**”, click “ **Auto snapshot ●** ”.
2. The auto snapshot can be set monthly, weekly, daily, or hourly.
3. Done. It will take snapshots automatically.

All
Months to take snapshots : 01 02 03 04
 05 06 07 08
 09 10 11 12

All
Weeks to take snapshots : 1 2 3 4
 5

All
Days to take snapshots : Sun Mon Tue Wed
 Thu Fri Sat

All
Hours to take snapshots : 00 01 02 03
 04 05 06 07
 08 09 10 11
 12 13 14 15
 16 17 18 19
 20 21 22 23

<< Back ●

Confirm ●



NOTE: Daily snapshot will be taken every 00:00. Weekly snapshot will be taken every Sunday 00:00. Monthly snapshot will be taken every first day of month 00:00.

4.4.3 Rollback

The data in snapshot VD can rollback to original VD. Please follow the steps.

1. Select “/ **Volume configuration / Snapshot**”.
2. Mouse moves to the gray button next to the Snap VD number which user wants to rollback the data; click “**Rollback**”.
3. Done, the data in snapshot VD will rollback to original VD.

Rollback has some constraints as described in the following:

1. Minimum RAM size required for enabling rollback is **1GB**.
2. When making a rollback, the original VD cannot be accessed for a while. At the same time, the system connects to original VD and snapshot VD, and then starts rollback.
3. During rollback, data from snapshot VD to original VD, the original VD can be accessed and the data in VD just like it has finished rollback. At the same time, the other related snap VD(s) can not be accessed.
4. After rollback, the other snapshot VD(s) after the VD which is doing rollback will be deleted.



IMPORTANT! Before executing rollback, it is better to dismount the file system for flushing data from cache to disks in OS first. System sends pop-up message when user executes rollback function.

4.5 Disk Roaming

Physical disks can be re-sequenced in the same system or move all physical disks from system-1 to system-2. This is called disk roaming. System can execute disk roaming online. Please follow these steps:

1. Select “/ **Volume configuration / RAID group**”.
2. Move the mouse pointer to the gray button next to the RG number; click “**Deactivate**”.
3. Move all PDs related to the RG to another system.
4. In the web GUI of the other system, move the mouse pointer to the gray button next to the RG number; click “**Activate**”.
5. Done.

Disk roaming has some constraints as described in the following:

1. Check the firmware of two systems first. It is better that both systems have the same firmware version or newer.
2. All physical disks of related RG should be moved from system-1 to system-2 together. The configuration of both RG and VD will be kept but LUN configuration will be cleared in order to avoid conflict with system-2.

4.6 SAS JBOD Expansion

This iSCSI RAID subsystem has SAS expansion port to connect to SAS JBOD Expansion chassis. When a SAS JBOD Expansion chassis is connected and detected, it displays tabs on the top in “/ **Volume configuration / Physical disk**”. For example: Local, JBOD 1 (vendor model), JBOD 2 (vendor model), ...etc. Local means disks in local controller, and so on. The disks in JBOD can be used as local disks.

Local JBOD 1 (iSCSI JBOD)

Slot	Size (GB)	RG name	Status	Health	Usage	Vendor	Serial	Type	Write cache	Standby
1	33		Online	Good	FR	HITACHI	J3XAB2S3	SAS	Enabled	Disabled
2	33		Online	Good	FR	HITACHI	J3XAE0D3	SAS	Enabled	Disabled
3	33		Online	Good	FR	HITACHI	J3XABBLJ	SAS	Enabled	Disabled
4	33		Online	Good	FR	HITACHI	J3XAB27J	SAS	Enabled	Disabled
5	33		Online	Good	FR	HITACHI	J3XAE9K3	SAS	Enabled	Disabled
6	33		Online	Good	FR	HITACHI	J3XAB4N3	SAS	Enabled	Disabled
7	33		Online	Good	FR	HITACHI	J3XAASK3	SAS	Enabled	Disabled
8	33		Online	Good	FR	HITACHI	J3XADGK3	SAS	Enabled	Disabled
9	68		Online	Good	FR	SEAGATE	3LQ0TJXX	SAS	Enabled	Disabled
10	68		Online	Good	FR	SEAGATE	3LQ0TLNR	SAS	Enabled	Disabled
11	68		Online	Good	FR	SEAGATE	3LQ0WDC7	SAS	Enabled	Disabled
12	68		Online	Good	FR	SEAGATE	3LQ1GX3E	SAS	Enabled	Disabled
13	68		Online	Good	FR	SEAGATE	3LQ0TL2D	SAS	Enabled	Disabled
14	68		Online	Good	FR	SEAGATE	3LQ0TLXN	SAS	Enabled	Disabled
15	68		Online	Good	FR	SEAGATE	3LQ0TKZH	SAS	Enabled	Disabled
16	68		Online	Good	FR	SEAGATE	3LQ0TMSF	SAS	Enabled	Disabled

“/ Enclosure management / S.M.A.R.T.” can displays S.M.A.R.T. information of all PDs, including Local and all SAS JBODs.

Local

Slot	HDD type	Read error rate	Spin up time	Reallocated sector count	Seek error rate	Spin up retries	Calibration retries	Temperature (C)
1	SATA	200(51)	121(21)	200(140)	200(51)	100(51)	100(51)	31
2	SATA	200(51)	120(21)	199(140)	200(51)	100(51)	100(51)	33
3	SATA	200(51)	119(21)	196(140)	200(51)	100(51)	100(51)	35
4	SATA	200(51)	121(21)	197(140)	200(51)	100(51)	100(51)	32
5	SATA	100(51)	100(25)	100(11)	100(51)	100(51)	96(0)	31
6	SATA	100(51)	100(25)	100(11)	100(51)	100(51)	100(0)	30
7	SATA	100(51)	100(25)	100(11)	100(51)	100(51)	100(0)	30
8	SATA2	100(16)	109(24)	100(5)	100(67)	100(60)	N/A	33
9	SATA	100(51)	100(25)	100(11)	100(51)	100(51)	100(0)	33
10	SATA	69(6)	98(0)	100(36)	88(30)	100(97)	N/A	37
11	SATA2	100(16)	108(24)	100(5)	100(67)	100(60)	N/A	34
12	SATA	95(60)	110(24)	100(5)	100(67)	100(60)	N/A	33
13	SATA2	200(51)	235(21)	200(140)	200(51)	100(51)	100(51)	39
14	SATA2	200(51)	238(21)	200(140)	200(51)	100(51)	100(51)	42
15	SATA2	103(6)	89(0)	100(36)	89(30)	100(97)	N/A	38
16	SATA2	102(6)	88(0)	100(36)	88(30)	100(97)	N/A	37

JBOD 1: iSCSI JBOD (WWN: 50013780029010BD)

Slot	HDD type	Read error rate	Spin up time	Reallocated sector count	Seek error rate	Spin up retries	Calibration retries	Temperature (C)
1	SAS	N/A	N/A	N/A	N/A	N/A	N/A	25
2	SAS	N/A	N/A	N/A	N/A	N/A	N/A	25
3	SAS	N/A	N/A	N/A	N/A	N/A	N/A	24
4	SAS	N/A	N/A	N/A	N/A	N/A	N/A	24
5	SAS	N/A	N/A	N/A	N/A	N/A	N/A	26
6	SAS	N/A	N/A	N/A	N/A	N/A	N/A	25
7	SAS	N/A	N/A	N/A	N/A	N/A	N/A	25
8	SAS	N/A	N/A	N/A	N/A	N/A	N/A	25
9	SAS	N/A	N/A	N/A	N/A	N/A	N/A	25
10	SAS	N/A	N/A	N/A	N/A	N/A	N/A	23
11	SAS	N/A	N/A	N/A	N/A	N/A	N/A	24
12	SAS	N/A	N/A	N/A	N/A	N/A	N/A	23
13	SAS	N/A	N/A	N/A	N/A	N/A	N/A	24
14	SAS	N/A	N/A	N/A	N/A	N/A	N/A	24
15	SAS	N/A	N/A	N/A	N/A	N/A	N/A	23
16	SAS	N/A	N/A	N/A	N/A	N/A	N/A	24

Figure shows Disk S.M.A.R.T. information of Local and JBOD 1; S.M.A.R.T. is supported in SATA disks only.

SAS JBOD expansion has some constraints as described in the following:

1. Up to 4 SAS JBODs can be cascaded.
2. When creating RG, member PDs must be located within the same enclosure. RG can not use PDs which are located in different enclosure. It means that RG can be composed of PDs which are all in same Local enclosure or one SAS JBOD enclosure.
3. Global spare disk only supports all RGs which are located in the same controller.

4.7 Support Microsoft MPIO and MC/S

MPIO (Multi-Path Input/Output) and **MC/S** (Multiple Connections per Session) use multiple physical paths to create logical "paths" between the server and the storage device. In case one or more of these components fail, causing the path to fail, multi-path logic uses an alternate path for I/O. So applications can still access the data.

Microsoft iSCSI initiator supports multi-path. Please follow the steps to use MPIO feature.

1. A host with dual LAN ports connects to the iSCSI RAID system.
2. Create a RG/VD and attach this VD to the host.
3. When installing "**Microsoft iSCSI initiator**", please install MPIO driver at the same time.
4. Logon to target separately on each port. When logon to target, check "**Enable multi-path**".
5. MPIO mode can be selected on Targets → Details → Devices → Advanced in Microsoft iSCSI initiator.
6. Rescan disk.
7. There will be one disk running MPIO.

Appendix

A. Certification list

❖ RAM

RAM Spec: 240-pin, DDR2-533(PC4300), Reg.(register) or UB(Unbuffered), ECC, up to 2GB, 64-bit data bus width (and also 32-bit memory support), x8 or x16 devices, 36-bit addressable, up to 14-bit row address and 10-bit column address.

Vendor	Model
ATP	AJ28K64E8BHE6S, 1GB DDR2-667 (Unbuffered, non-ECC) with SEC
ATP	AJ28K72G8BHE6S, 1GB DDR2-667 (Unbuffered, ECC) with SEC
ATP	AJ64K72F8BHE6S, 512MB DDR2-667 (Unbuffered, ECC) with SEC
ATP	AJ56K72G8BJE6S, 2GB DDR2-667 (Unbuffered, ECC) with Samsung
Unigen	UG64T7200L8DU-6AL, 512MB DDR2-667 (Unbuffered, ECC) with Elpida
Unigen	UG12T7200L8DU-5AM, 1GB DDR2-533 (Unbuffered, ECC) with Elpida
Unigen	UG12T7200L8DR-5AC, 1GB DDR2-533 (Registered, ECC) with Elpida
Unigen	UG25T7200M8DU-5AM, 2GB DDR2-533 (Unbuffered, ECC) with Micron

❖ iSCSI Initiator (Software)

OS	Software/Release Number
Microsoft Windows	Microsoft iSCSI Software Initiator Release v2.07 System Requirements: <ol style="list-style-type: none">1. Windows 2000 Server with SP42. Windows Server 2003 with SP23. Windows Server 2003 R2 with SP24. Windows Server 2008
Linux	The iSCSI Initiators are different for different Linux Kernels. <ol style="list-style-type: none">1. For Red Hat Enterprise Linux 3 (Kernel 2.4), install linux-iscsi-3.6.3.tar2. For Red Hat Enterprise Linux 4 (Kernel 2.6), use the build-in iSCSI initiator iscsi-initiator-utils-4.0.3.0-4 in kernel 2.6.93. For Red Hat Enterprise Linux 5 (Kernel 2.6), use the build-in iSCSI initiator iscsi-initiator-utils-6.2.0.742-0.5.el5 in kernel 2.6.18

Mac	ATTO Xtend SAN iSCSI initiator v3.10 System Requirements: 1. Mac OS X v10.5 or later
-----	--

For ATTO Xtend SAN iSCSI initiator, it is not free. Please contact your local distributor.

❖ **iSCSI HBA card**

Vendor	Model
HP	NC380T (PCI-Express, Gigabit, 2 ports, TCP/IP offload, iSCSI offload)
QLogic	QLA4010C (PCI-X, Gigabit, 1 port, TCP/IP offload, iSCSI offload)
QLogic	QLA4052C (PCI-X, Gigabit, 2 ports, TCP/IP offload, iSCSI offload)

❖ **NIC**

Vendor	Model
HP	NC7170 (PCI-X, Gigabit, 2 ports)
HP	NC360T (PCI-Express, Gigabit, 2 ports, TCP/IP offload)
IBM	NetXtreme 1000 T (73P4201) (PCI-X, Gigabit, 2 ports, TCP/IP offload)
Intel	PWLA8492MT (PCI-X, Gigabit, 2 ports, TCP/IP offload)

❖ **GbE Switch**

Vendor	Model
Dell	PowerConnect 5324
Dell	PowerConnect 2724
Dell	PowerConnect 2708
HP	ProCurve 1800-24G

❖ **Hard drive**

The iSCSI RAID system supports SATA I and SATA II drives.

Vendor	Model
Hitachi	Deskstar 7K250, HDS722580VLSA80, 80GB, 7200RPM, SATA, 8M
Hitachi	Deskstar E7K500, HDS725050KLA360, 500GB, 7200RPM, SATA II, 16M
Hitachi	Deskstar 7K80, HDS728040PLA320, 40GB, 7200RPM, SATA II, 2M
Hitachi	Deskstar T7K500, HDT725032VLA360, 320GB, 7200RPM, SATA II, 16M
Hitachi	Deskstar P7K500, HDP725050GLA360, 500GB, 7200RPM, SATA

	II, 16M
Maxtor	DiamondMax Plus 9, 6Y080M0, 80GB, 7200RPM, SATA, 8M
Maxtor	DiamondMax 11, 6H500F0, 500GB, 7200RPM, SATA 3.0Gb/s, 16M
Samsung	SpinPoint P80, HDSASP0812C, 80GB, 7200RPM, SATA, 8M
Seagate	Barracuda 7200.7, ST380013AS, 80GB, 7200RPM, SATA 1.5Gb/s, 8M
Seagate	Barracuda 7200.7, ST380817AS, 80GB, 7200RPM, SATA 1.5Gb/s, 8M, NCQ
Seagate	Barracuda 7200.8, ST3400832AS, 400GB, 7200RPM, SATA 1.5Gb/s, 8M, NCQ
Seagate	Barracuda 7200.9, ST3500641AS, 500GB, 7200RPM, SATA 3.0Gb/s, 16M, NCQ
Seagate	Barracuda 7200.11, ST31000340AS, 1000GB, 7200RPM, SATA 3.0Gb/s, 32M, NCQ
Seagate	NL35, ST3400633NS, 400GB, 7200RPM, SATA 3.0Gb/s, 16M
Seagate	NL35, ST3500641NS, 500GB, 7200RPM, SATA 3.0Gb/s, 16M
Seagate	Barracuda ES, ST3500630NS, 500GB, 7200RPM, SATA 3.0Gb/s, 16M
Seagate	Barracuda ES, ST3750640NS, 750GB, 7200RPM, SATA 3.0Gb/s, 16M
Seagate	Barracuda ES.2, ST31000340NS, 1000GB, 7200RPM, SATA 3.0Gb/s, 32M
Western Digital	Caviar SE, WD800JD, 80GB, 7200RPM, SATA 3.0Gb/s, 8M
Western Digital	Caviar SE, WD1600JD, 160GB, 7200RPM, SATA 1.5G/s, 8M
Western Digital	Raptor, WD360GD, 36.7GB, 10000RPM, SATA 1.5Gb/s, 8M
Western Digital	Caviar RE2, WD4000YR, 400GB, 7200RPM, SATA 1.5Gb/s, 16M, NCQ
Western Digital	RE2, WD4000YS, 400GB, 7200RPM, SATA 3.0Gb/s, 16M
Western Digital	Caviar RE16, WD5000AAKS, 500GB, 7200RPM, SATA 3.0Gb/s, 16M
Western Digital	RE2, WD5000ABYS, 500GB, 7200RPM, SATA 3.0Gb/s, 16M, NCQ

The iSCSI RAID system supports SAS drives.

Vendor	Model
Hitachi	Ultrastar 15K147, HUS151436VLS300, 36GB, 15000RPM, SAS 3.0Gb/s, 16M
Seagate	Cheetah 15K.4, ST336754SS, 36.7GB, 15000RPM, SAS 3.0Gb/s, 8M
Seagate	Cheetah 15K.5, ST373455SS, 73.4GB, 15000RPM, SAS 3.0Gb/s, 16M
Seagate	Cheetah 15K.5, ST3146855SS, 146.8GB, 15000RPM, SAS 3.0Gb/s, 16M
Seagate	Cheetah NS, ST3400755SS, 400GB, 10000RPM, SAS 3.0Gb/s, 16M
Seagate	Barracuda ES.2, ST31000640SS, 1000GB, 7200RPM, SAS 3.0Gb/s, 16M

B. Event Notifications

❖ PD events

Level	Type	Description
INFO	Disk inserted	Disk <slot> is inserted into system.
WARNING	Disk removed	Disk <slot> is removed from system.
ERROR	HDD failure	Disk <slot> is disabled.

❖ HW events

Level	Type	Description
WARNING	ECC error	Single-bit ECC error is detected.
ERROR	ECC error	Multi-bit ECC error is detected.
INFO	ECC info	ECC memory is installed.
INFO	ECC info	Non-ECC memory is installed.
INFO	SCSI info	Received SCSI Bus Reset event at the SCSI Bus <number>.

❖ EMS events

Level	Type	Description
INFO	Power installed	Power <number> is installed.
ERROR	Power absent	Power <number> is absent.
INFO	Power work	Power <number> is restored to work.
ERROR	Power warning	Power <number> is out of work.
WARNING	Power detect	PSU signal detection <number>.
INFO	Fan work	Fan <number> is restored to work.
ERROR	Fan warning	Fan <number> is out of work.
INFO	Fan installed	Fan <number> is installed.
ERROR	Fan not present	Fan <number> is not present.
WARNING	Thermal warning	System temperature <location> is a little bit higher.
ERROR	Thermal critical	System Overheated <location>!!!
ERROR	Thermal critical shutdown	System Overheated <location>!!! The system will do the auto shutdown immediately.
WARNING	Thermal ignore value	Unable to update thermal value on <location>.
WARNING	Voltage warning	System voltage <location> is a little bit higher/lower.
ERROR	Voltage critical	System voltages <location> failed!!!
ERROR	Voltage critical shutdown	System voltages <location> failed!!! The system will do the auto shutdown immediately.
INFO	UPS info	UPS detection succeeded.
WARNING	UPS error	UPS detection failed.
ERROR	UPS error	AC loss for the system is detected.
ERROR	UPS error	UPS Power Low!!! The system will do the auto shutdown immediately.
WARNING	SMART T.E.C.	Disk <slot> S.M.A.R.T. Threshold Exceed Condition occurred for attribute <item>.

WARNING	SMART failure	Disk <slot>: Failure to get S.M.A.R.T information.
----------------	---------------	--

❖ **RMS events**

Level	Type	Description
INFO	Console Login	<username> login from <IP or serial console> via Console UI.
INFO	Console Logout	<username> logout from <IP or serial console> via Console UI.
INFO	Web Login	<username> login from <IP> via Web UI.
INFO	Web Logout	<username> logout from <IP> via Web UI.

❖ **LVM3 events**

Level	Type	Description
INFO	RG created	RG <name> has been created.
INFO	RG creation failed	Failed to create RG <name>.
INFO	RG deleted	RG <name> has been deleted.
INFO	VD created	VD <name> has been created.
INFO	VD creation failed	Failed to create VD <name>.
INFO	VD deleted	VD <name> has been deleted.
INFO	VD renamed	Name of VD <name> has been renamed to <name>.
INFO	Read-only caching enabled	Cache policy of VD <name> has been set as read only.
INFO	Writeback caching enabled	Cache policy of VD <name> has been set as write-back.
INFO	Write-through caching enabled	Cache policy of VD <name> has been set as write-through.
INFO	VD extended	Size of VD <name> extends.
INFO	VD initialization started	VD <name> starts initialization.
INFO	VD initialization finished	VD <name> completes the initialization.
WARNING	VD initialization failed	Failed to complete initialization of VD <name>.
INFO	VD rebuild started	VD <name> starts rebuilding.
INFO	VD rebuild finished	VD <name> completes rebuilding.
WARNING	VD rebuild failed	Failed to complete rebuild of VD <name>.
INFO	VD migration started	VD <name> starts migration.
INFO	VD migration finished	VD <name> completes migration.
ERROR	VD migration failed	Failed to complete migration of VD <name>.
INFO	VD scrubbing started	VD <name> starts scrubbing.
INFO	VD scrubbing finished	VD <name> completes scrubbing.

INFO	RG migration started	RG <name> starts migration.
INFO	RG migration finished	RG <name> completes migration.
INFO	RG activated	RG <name> has been manually activated.
INFO	RG deactivated	RG <name> has been manually deactivated.
INFO	VD rewrite started	Rewrite at LBA <address> of VD %s starts.
INFO	VD rewrite finished	Rewrite at LBA <address> of VD %s completes.
WARNING	VD rewrite failed	Rewrite at LBA <address> of VD %s failed.
WARNING	RG degraded	RG <name> is under degraded mode.
WARNING	VD degraded	VD <name> is under degraded mode.
ERROR	RG failed	RG <name> is failed.
ERROR	VD failed	VD <name> is failed.
WARNING	Recoverable read error occurred	Recoverable read error occurred at LBA <address>-<address> of VD <name>.
WARNING	Recoverable write error occurred	Recoverable write error occurred at LBA <address>-<address> of VD <name>.
ERROR	Unrecoverable read error occurred	Unrecoverable read error occurred at LBA <address>-<address> of VD <name>.
ERROR	Unrecoverable write error occurred	Unrecoverable write error occurred at LBA <address>-<address> of VD <name>.
INFO	Dedicated spare configured	PD <slot> has been configured to RG <name> as a dedicated spare disk.
INFO	Global spare configured	PD <slot> has been configured as a global spare disk.
WARNING	PD read error occurred	Read error occurred at LBA <address>-<address> of PD <slot>.
WARNING	PD write error occurred	Write error occurred at LBA <address>-<address> of PD <slot>.
WARNING	Parity wrong when scrubbing	The parity data is wrong at LBA <address>-<address> when scrubbing VD <name>.
WARNING	Data recovered when scrubbing	Data at LBA <address>-<address> has been recovered when scrubbing VD <name>.
INFO	PD freed	PD <slot> has been removed from RG <name>.
INFO	RG imported	Configuration of RG<name> has been imported.
INFO	RG restored	Configuration of RG <name> has been restored.
INFO	VD restored	Configuration of VD <name> has been restored.

❖ **Snapshot events**

Level	Type	Description
INFO	Snapshot deleted	The snapshot VD <name> has been deleted.
INFO	Snapshot auto	The oldest snapshot VD <name> has been

	deleted	deleted to obtain extra snapshot space.
INFO	Snapshot taken	A snapshot on VD <name> has been taken.
INFO	Snapshot space configured	Set the snapshot space of VD <name> to <number> MB.
INFO	Snapshot rollback started	Snapshot rollback of VD <name> has been started.
INFO	Snapshot rollback finished	Snapshot rollback of VD <name> has been finished.
WARNING	Snapshot quota reached	The quota assigned to snapshot <name> is reached.

❖ **iSCSI events**

Level	Type	Description
INFO	iSCSI login succeeds	iSCSI login from <IP> succeeds.
INFO	iSCSI login rejected	iSCSI login from <IP> was rejected, reason [<string>]
INFO	iSCSI logout	iSCSI logout from <IP> was received, reason [<string>].

❖ **Battery backup events**

Level	Type	Description
INFO	BBM sync data	Abnormal shutdown detected, start flushing battery-backup data (<number> KB).
INFO	BBM sync data	Abnormal shutdown detected, flushing battery-backup data finishes.
INFO	BBM detected	Battery backup module is detected.
INFO	BBM is good	Battery backup module is good.
INFO	BBM is charging	Battery backup module is charging.
WARNING	BBM is failed	Battery backup module is failed.
INFO	BBM	Battery backup feature is <item>.

❖ **JBOD events**

Level	Type	Description
INFO	Disk inserted	JBOD <number> disk <slot> is inserted into system.
Warning	Disk removed	JBOD <number> disk <slot> is removed from system.
ERROR	HDD failure	JBOD <number> disk <slot> is disabled.
INFO	JBOD inserted	JBOD <number> is inserted into system
WARNING	JBOD removed	JBOD <number> is removed from system
WARNING	SMART T.E.C	JBOD <number> disk <slot>: S.M.A.R.T. Threshold Exceed Condition occurred for attribute %s
WARNING	SMART Failure	JBOD <number> disk <slot>: Failure to get S.M.A.R.T information
INFO	Dedicated spare configured	JBOD <number> PD <slot> has been configured to RG <name> as a dedicated spare disk.

INFO	Global spare configured	JBOD <number> PD <slot>d has been configured as a global spare disk.
WARNING	PD read error occurred	Read error occurred at LBA <address>-<address> of JBOD <number> PD <slot>.
WARNING	PD write error occurred	Write error occurred at LBA <address>-<address> of JBOD <number> PD <slot>.
INFO	PD freed	JBOD <number> PD <slot> has been removed from RG <name>.

❖ **System maintenance events**

Level	Type	Description
INFO	System shutdown	System shutdown.
INFO	System reboot	System reboot.
INFO	FW upgrade start	Firmware upgrade start.
INFO	FW upgrade success	Firmware upgrade success.
WARNING	FW upgrade failure	Firmware upgrade failure.

C. Known issues

1. Microsoft MPIO driver is not supported on Windows XP and Windows 2000 Professional.

Workaround solution: Use Windows Server 2008/2003 or Windows 2000 Server to run MPIO.

2. When two controllers (with SAS JBOD expansion ports) connect to JBOD expansion chassis (SAS JBOD), they can not detect all PDs of JBOD.

Workaround solution: It's a JBOD limitation.

D. Microsoft iSCSI Initiator

Here is the step by step to setup Microsoft iSCSI Initiator. Please visit Microsoft website for latest iSCSI initiator. The following setup may not use the latest Microsoft iSCSI initiator.

1. Run Microsoft iSCSI Initiator.
2. Click **“Discovery”**.
3. Click **“Add”**. Input IP address or DNS name of iSCSI storage device.

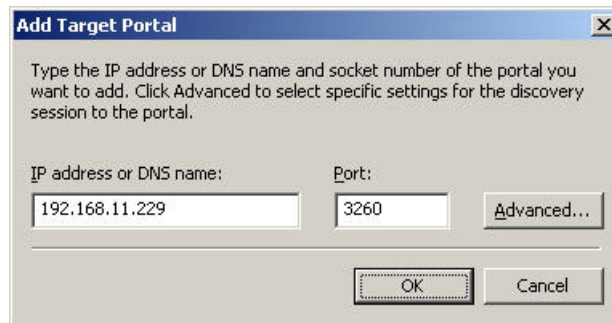

4. Click **“OK”**.
5. Click **“Targets”**.

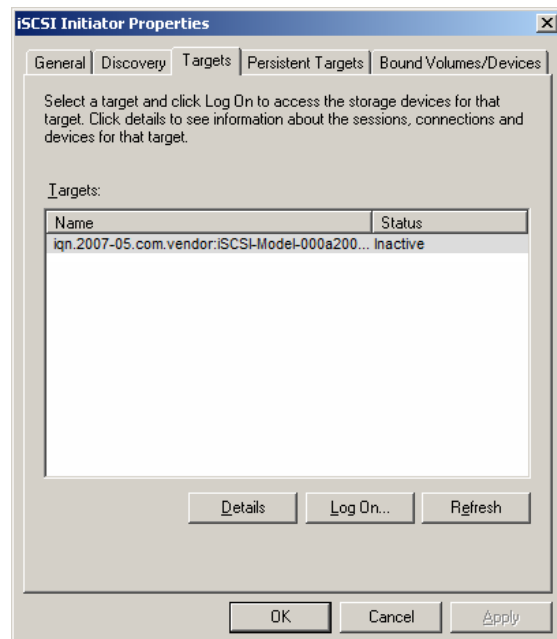
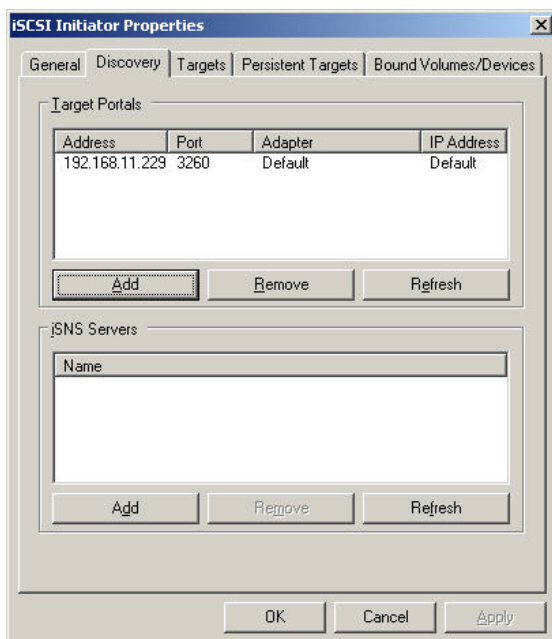

6. Click **“Log On”**. Check **“Enable multi-path”** if running MPIO.

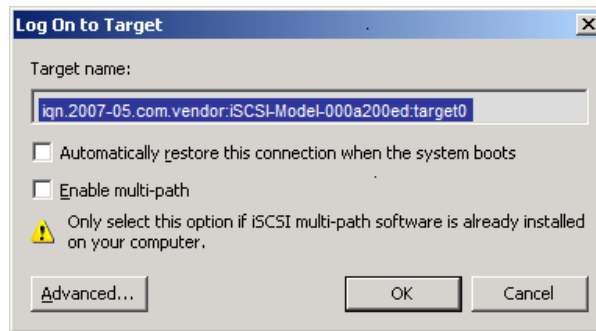

7. Click **“Advance...”** if CHAP information is needed.
8. Click **“OK”**. The status would be **“Connected”**.
9. Done, it can connect to an iSCSI disk.

The following procedure is to log off iSCSI device.

1. Click **“Details”** in **“Targets”**.
2. Check the Identifier, which will be deleted.
3. Click **“Log off”**.
4. Done, the iSCSI device is logged off successfully.

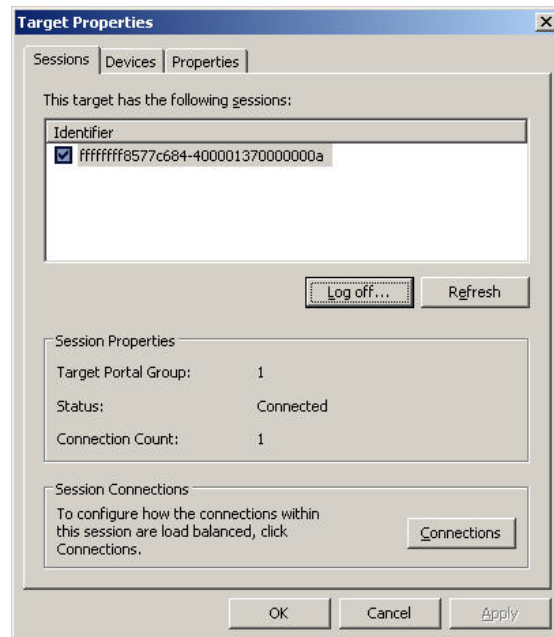
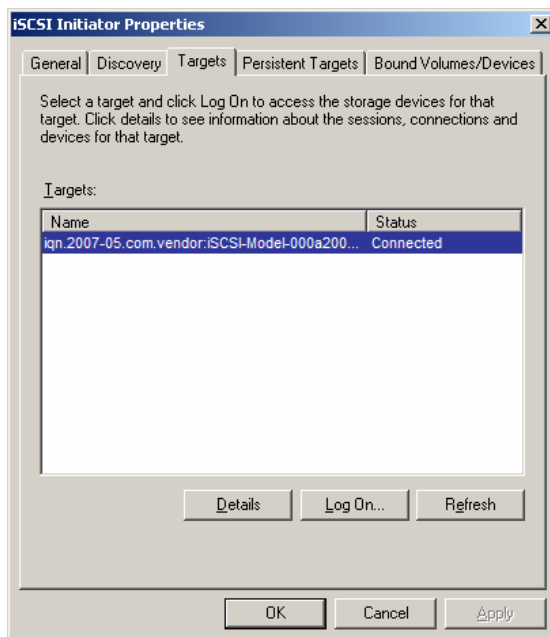

E. Installation steps for large volume (over 2TB)

Introduction:

This iSCSI RAID subsystem is capable of supporting large volumes (>2TB). When connecting the iSCSI RAID system to host/server with 64bit OS installed, the host/server is inherently capable for large volumes from the 64bit address. On the other side, if the host/server is installed with 32bit OS, user has to change the block size to 1KB, 2KB or 4KB to support volumes up to 4TB, 8TB or 16TB, for the 32bit host/server is not LBA (Logical Block Addressing) 64bit supported. For detailed installation steps, please refer to following steps below.

Step 1: Configure target

1. Prepare the hard drivers whose total capacity will be over 2TB. Follow the example in chapter 3 to create a RG/VD. Then attach LUN.



NOTE: If the OS is 64bit, user can set the block size to any available value. If the OS is 32bit, user must change the block size to larger values than 512B. There will be a confirmation pop-up message when VD size is over 2TB.

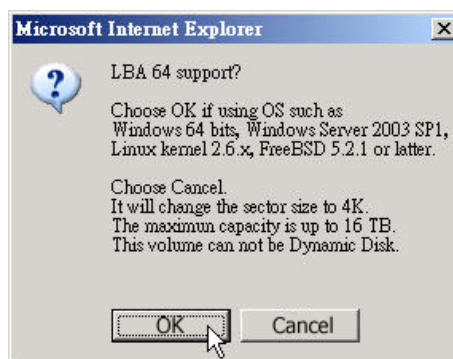

In the figure above, choose "OK" for 64bit OS, choose "Cancel" for 32bit OS, this step will change block size to 4K automatically.

2. Move the mouse pointer to the gray button next to the VD number; click "More information". Look at the block size; 512B for 64bit OS setting, 4K for 32bit OS setting.

Step 2: Configure host/server

1. Follow the installation guide provided by HBA vendor, install HBA driver properly. For iSCSI models, please install the latest Microsoft iSCSI initiator from the link below.

<http://www.microsoft.com/downloads/details.aspx?FamilyID=12cb3c1a-15d6-4585-b385-befd1319f825&DisplayLang=en>

Step 3: Initialize/Format/Mount the disk

1. Go to Start → Control Panel → Computer Management → Disk Management, it displays a new disk.

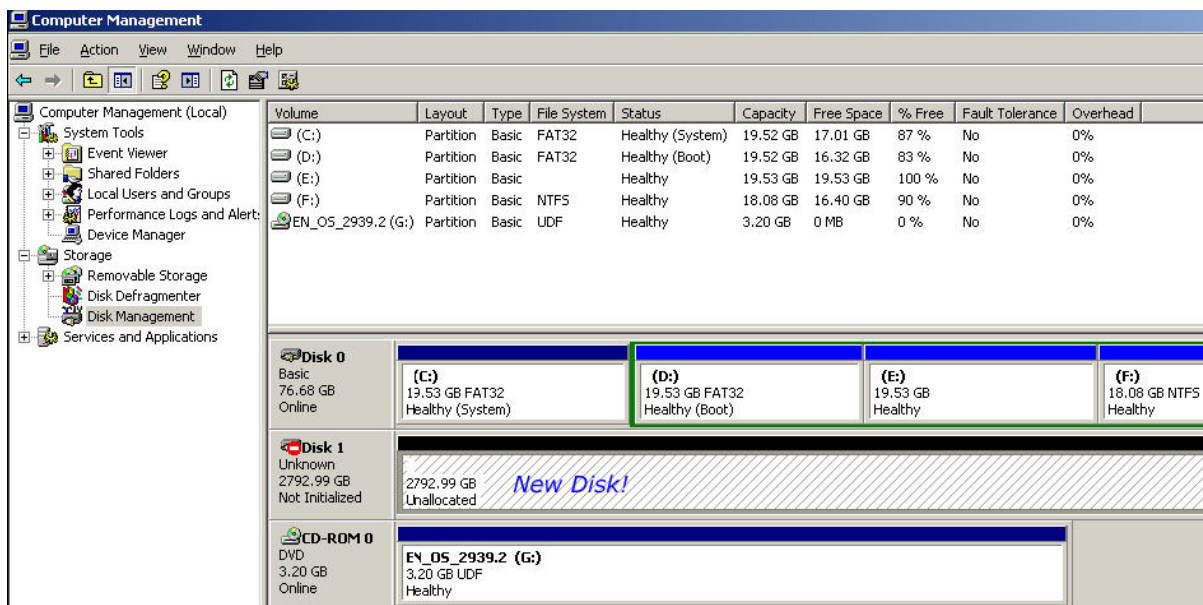

2. Initialize the disk.



- Convert to GPT disk for over 2TB capacity. For more detail information about GPT, please visit

http://www.microsoft.com/whdc/device/storage/GPT_FAQ.msp

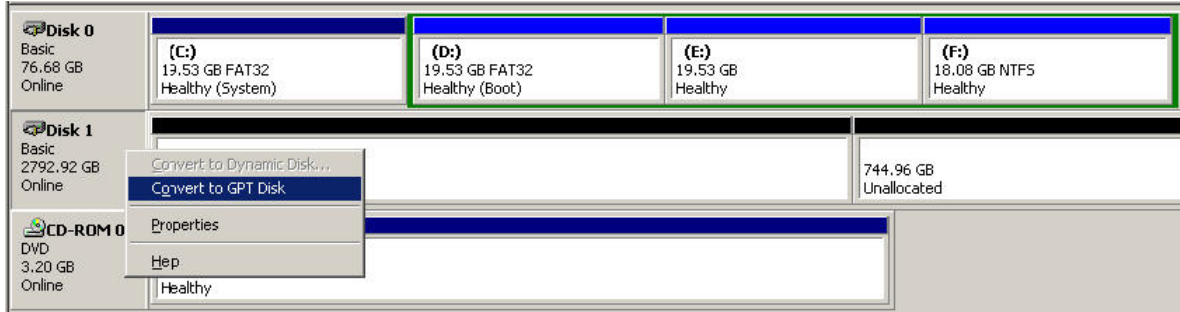

- Format the disk.

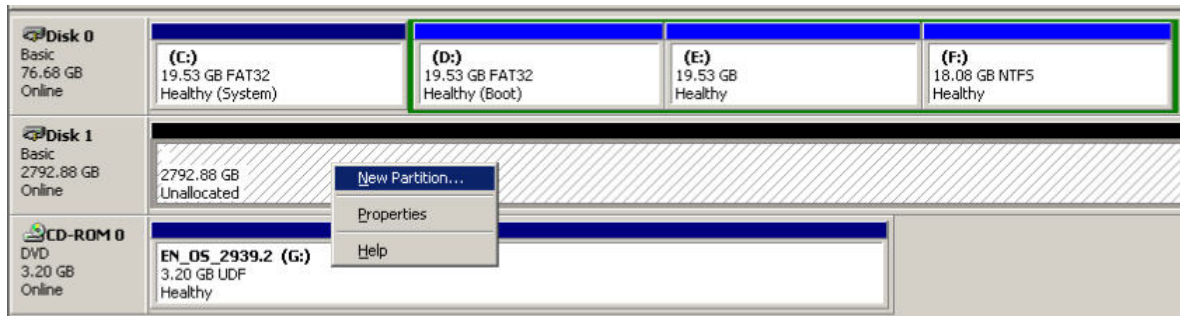

- Done.

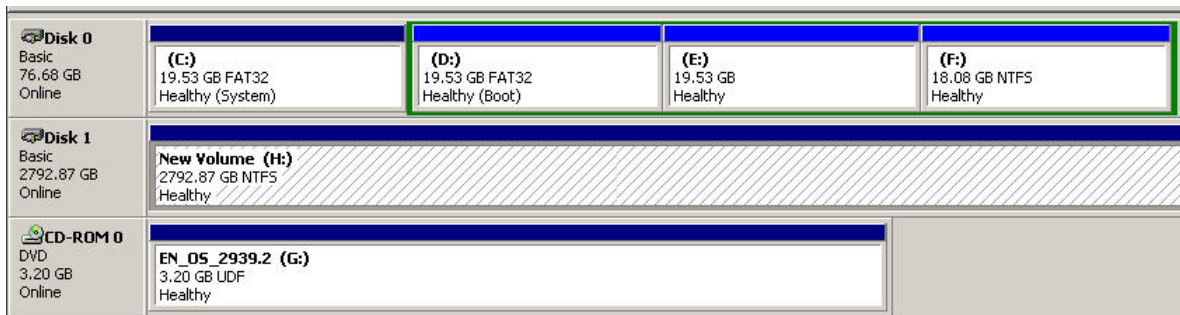

- The new disk is ready to be used, with available size = 2.72TB.

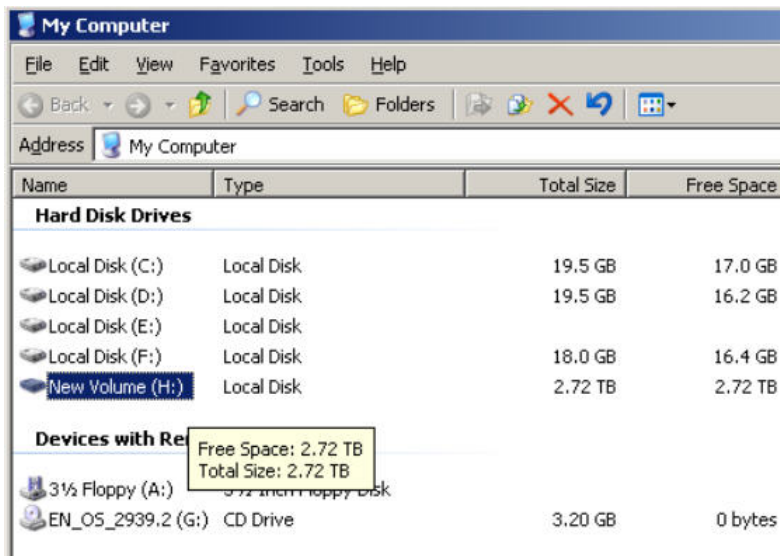

WARNING! If VD is setup using 512B block size and the host/server OS is 32bit, in the last step of formatting disk, the OS cannot format the disk sector after 2048GB (2TB).

- Wrong setting result: OS can not format disk sector after 2048GB(2TB).

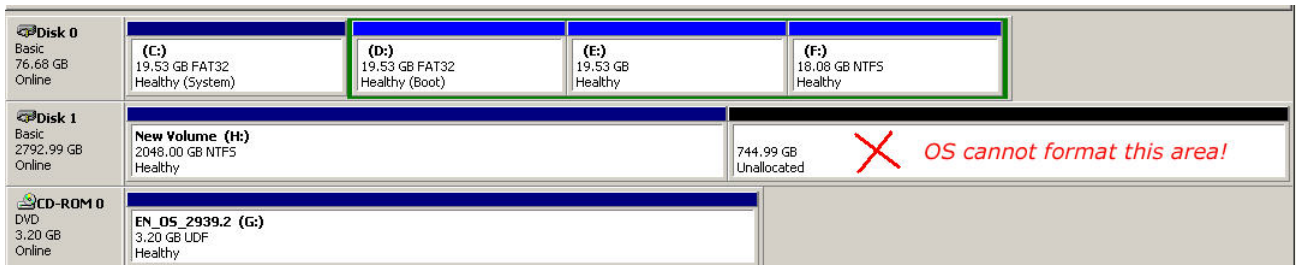

F. MPIO and MC/S setup instructions

Here is the instruction to setup MPIO or MC/S. The following network diagrams are the examples. Please follow them to setup the environment. Be reminded that the host must have multiple NICs which are set up with different IPs.

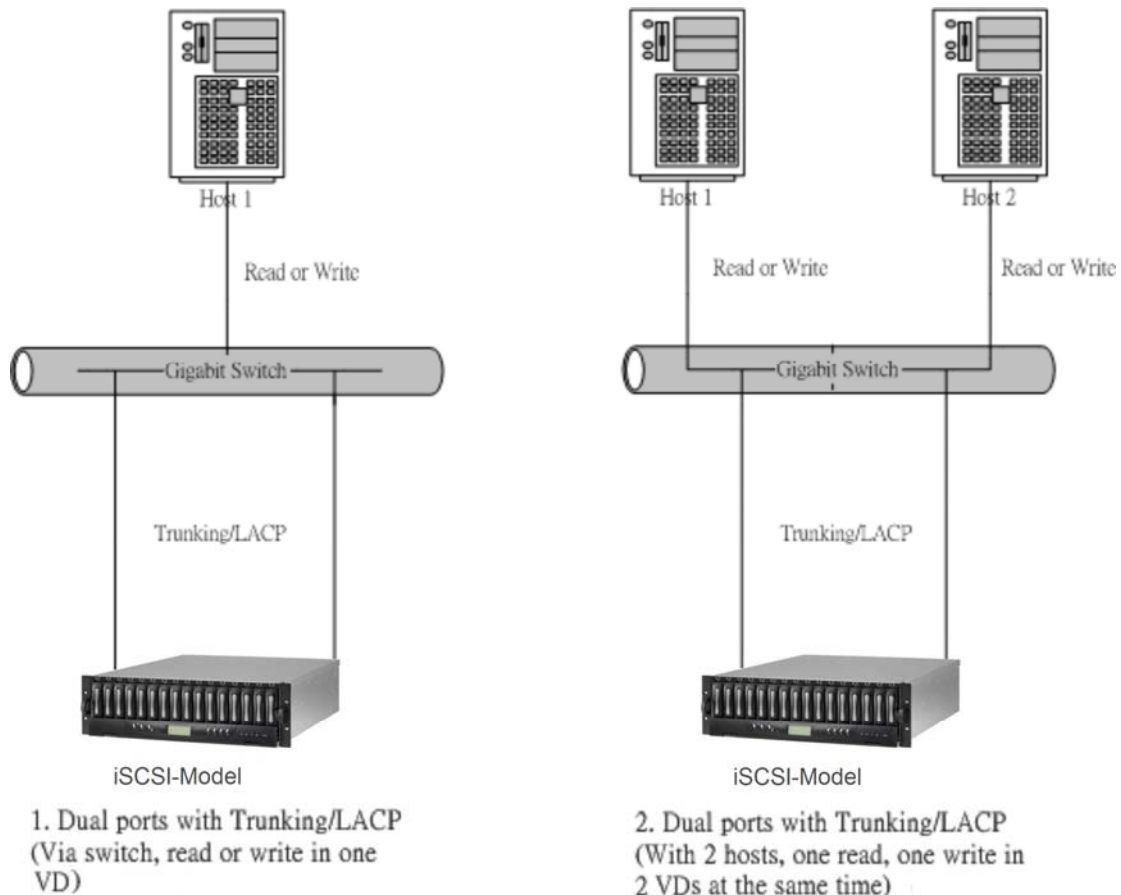

The MPIO setup instructions are in the following:

1. Create RG/VD, and then attach LUN.
2. Add the first "Target Portal" on Microsoft iSCSI initiator.
3. Add the second "Target Portal" on Microsoft iSCSI initiator.
4. Logon.
5. Enable "**Enable multi-path**" checkbox. Then click "**Advanced...**".
6. Select the first "Source IP" and "Target Portal" to iSCSI data port 1. Then click "**OK**".
7. Logon again.
8. Enable "**Enable multi-path**" checkbox. Then click "**Advanced...**".
9. Select the second "Source IP" and "Target Portal" to iSCSI data port 2. Then click "**OK**".
10. iSCSI device is connected. Click "**Details**".
11. Click "**Device**" tab, then click "**Advanced**".
12. Click "**MPIO**" tab, select "**Load Balance Policy**" to "**Round Robin**".

-
13. Click "**Apply**".
 14. Run "**Device Manage**" in Windows. Make sure MPIO device is available.
 15. Done.

The MC/S setup instructions are in the following:

1. Create RG/VD, and then attach LUN.
2. Add the first "Target Portal" on Microsoft iSCSI initiator, For MC/S, there is only ONE "**Target Portals**" in the "**Discovery**" tab.
3. Logon.
4. Then click "**Advanced...**".
5. Select the first "Source IP" and "Target Portal" to iSCSI data port 1. Then click "**OK**".
6. After connected, click "**Details**", then in the "**Session**" tab, click "**Connections**".
7. Choose "**Round Robin**" in "**Load Balance Policy**".
8. "**Add**" Source Portal for the iSCSI data port 2.
9. Select the second "Source IP" and "Target Portal" to iSCSI data port 2. Then select "**OK**".
10. Done.

G. Trunking / LACP setup instructions

Here is the instruction to setup Trunking and LACP. The following network diagrams are the examples. Please follow them to setup the environment. Remind that gigabit switch must support trunking or LACP; otherwise these functions can not work. The running path in trunking or LACP mode is decided by an operation of MAC addresses of host and target. It's better to prepare two or more hosts. Fortunately the performance can be increased obviously.

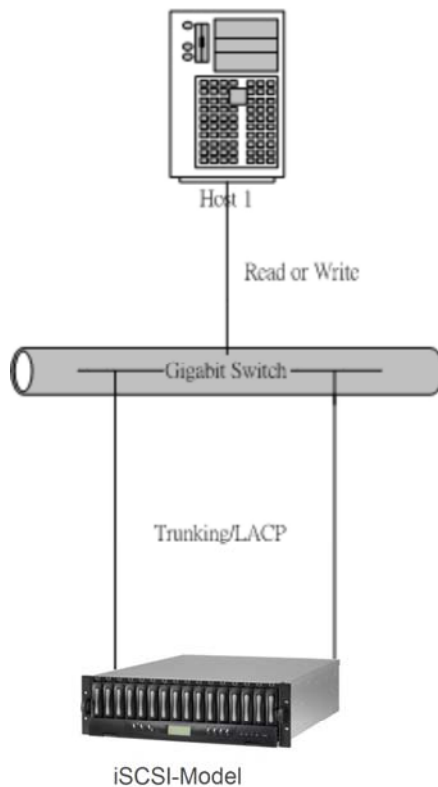

1. Dual ports with Trunking/LACP
(Via switch, read or write in one VD)

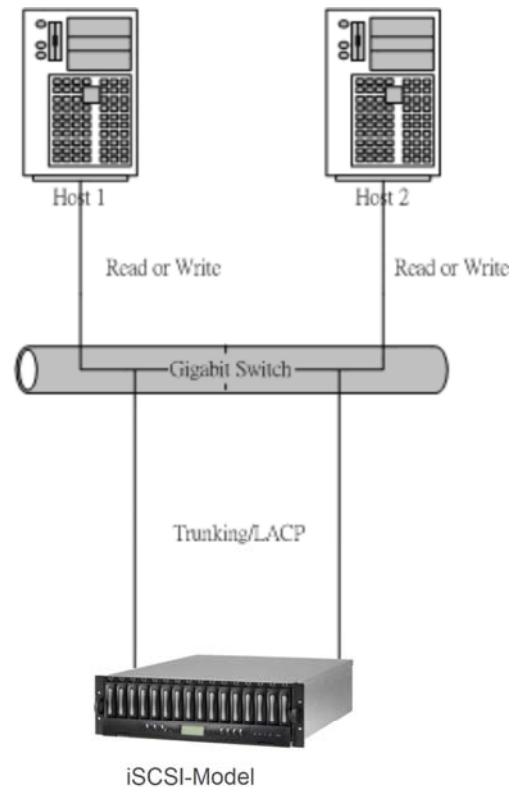

2. Dual ports with Trunking/LACP
(With 2 hosts, one read, one write in 2 VDs at the same time)

The setup instructions are in the following:

1. In “/ iSCSI configuration / NIC”, click the button “ **Aggregation** ”.
2. Decide to use Trunking or LACP, and then select at least two NICs for link aggregation. For example.

Aggregation :	<input checked="" type="radio"/> Trunking <input type="radio"/> LACP
Address :	192.168.1.1
Mask :	255.255.255.0
Gateway :	192.168.1.254
NIC :	<input type="checkbox"/> LAN1 <input type="checkbox"/> LAN2 <input type="checkbox"/> LAN3 <input type="checkbox"/> LAN4

-
3. Enable Trunking or LACP of ports which are connected to target iSCSI ports in gigabit switch.
 4. Create RG/VD, and then attach LUN.
 5. Logon by Microsoft iSCSI initiator.
 6. Done.