

# SUPERO®

## SC825 CHASSIS Series

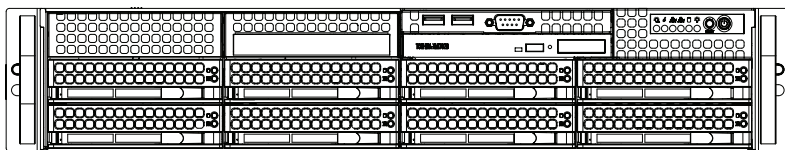

SC825TQ-R740WB	SC825TQ-R740UB
SC825TQ-R720LPB	SC825TQ-R740LPB
SC825TQ-710LP(V)(B)	SC825TQ-R720UB
SC825TQ-R700LP(V)(B)	SC825TQ-R700U(V)(B)
SC825TQ-600LPB	SC825TQ-563UB
SC825TQ-563LPB	SC825TQ-560LP(V)(B)
SC825TQ-560U(V)(B)	

## USER'S MANUAL

1.0c

The information in this User's Manual has been carefully reviewed and is believed to be accurate. The vendor assumes no responsibility for any inaccuracies that may be contained in this document, makes no commitment to update or to keep current the information in this manual, or to notify any person or organization of the updates. **Please Note: For the most up-to-date version of this manual, please see our web site at [www.supermicro.com](http://www.supermicro.com).**

Super Micro Computer, Inc. ("Supermicro") reserves the right to make changes to the product described in this manual at any time and without notice. This product, including software and documentation, is the property of Supermicro and/or its licensors, and is supplied only under a license. Any use or reproduction of this product is not allowed, except as expressly permitted by the terms of said license.

IN NO EVENT WILL SUPERMICRO BE LIABLE FOR DIRECT, INDIRECT, SPECIAL, INCIDENTAL, SPECULATIVE OR CONSEQUENTIAL DAMAGES ARISING FROM THE USE OR INABILITY TO USE THIS PRODUCT OR DOCUMENTATION, EVEN IF ADVISED OF THE POSSIBILITY OF SUCH DAMAGES. IN PARTICULAR, SUPERMICRO SHALL NOT HAVE LIABILITY FOR ANY HARDWARE, SOFTWARE, OR DATA STORED OR USED WITH THE PRODUCT, INCLUDING THE COSTS OF REPAIRING, REPLACING, INTEGRATING, INSTALLING OR RECOVERING SUCH HARDWARE, SOFTWARE, OR DATA.

Any disputes arising between manufacturer and customer shall be governed by the laws of Santa Clara County in the State of California, USA. The State of California, County of Santa Clara shall be the exclusive venue for the resolution of any such disputes. Super Micro's total liability for all claims will not exceed the price paid for the hardware product.

California Best Management Practices Regulations for Perchlorate Materials: This Perchlorate warning applies only to products containing CR (Manganese Dioxide) Lithium coin cells. "Perchlorate Material-special handling may apply. See [www.dtsc.ca.gov/hazardouswaste/perchlorate](http://www.dtsc.ca.gov/hazardouswaste/perchlorate)"

---

**WARNING: Handling of lead solder materials used in this product may expose you to lead, a chemical known to the State of California to cause birth defects and other reproductive harm.**

---

Manual Revision 1.0c  
Release Date: June 286, 2012

Unless you request and receive written permission from Super Micro Computer, Inc., you may not copy any part of this document.

Information in this document is subject to change without notice. Other products and companies referred to herein are trademarks or registered trademarks of their respective companies or mark holders.

Copyright © 2012 by Super Micro Computer, Inc.  
All rights reserved.

**Printed in the United States of America**

---

## Preface

### About This Manual

This manual is written for professional system integrators and PC technicians. It provides information for the installation and use of the SC825 2U chassis. Installation and maintenance should be performed by experienced technicians only.

Supermicro's SC825 2U chassis features a unique and highly optimized design. The chassis is equipped with a 560W (single), 563W (single), 600W (single), 700W (redundant), 710W (single), 720W (redundant) or 740W (redundant) high-efficiency power supply for superb power savings. High-performance fans provide ample optimized cooling for the chassis.

This document lists compatible parts and configurations available when this document was published. Always refer to the our Web site for updates on supported parts and configurations.

## **Manual Organization**

### **Chapter 1 Introduction**

The first chapter provides a checklist of the main components included with this chassis and describes the main features of the SC825 chassis. This chapter also includes contact information.

### **Chapter 2 System Safety**

This chapter lists warnings, precautions, and system safety. You should thoroughly familiarize yourself with this chapter for a general overview of safety precautions that should be followed before installing and servicing this chassis.

### **Chapter 3 Chassis Components**

Refer here for details on this chassis model including the fans, bays, airflow shields, and other components.

### **Chapter 4 System Interface**

Refer to this chapter for details on the system interface, which includes the functions and information provided by the control panel on the chassis as well as other LEDs located throughout the system.

### **Chapter 5 Chassis Setup and Maintenance**

Refer to this chapter for detailed information on this chassis. You should follow the procedures given in this chapter when installing, removing, or reconfiguring your chassis.

### **Chapter 6 Rack Installation**

Refer to this chapter for detailed information on chassis rack installation. You should follow the procedures given in this chapter when installing, removing or reconfiguring your chassis into a rack environment.

## **Appendices**

This section lists compatible cables, power supply specifications, and compatible backplanes. Not all compatible backplanes may be listed. Refer to our Web site for the latest compatible backplane information.

# Table of Contents

## **Chapter 1 Introduction**

1-1	Overview .....	1-1
1-2	Shipping List.....	1-1
1-3	Chassis Features .....	1-2
	CPU.....	1-2
	Hard Drives .....	1-2
	I/O Expansion slots .....	1-2
	Peripheral Drives.....	1-2
	Other Features .....	1-2
	SCSI Chassis Models .....	1-2
1-4	Contacting Supermicro.....	1-3
1-5	Returning Merchandise for Service.....	1-4

## **Chapter 2 System Safety**

2-1	Overview .....	2-1
2-2	Warnings and Precautions .....	2-1
2-3	Preparing for Setup.....	2-1
2-4	Electrical Safety Precautions .....	2-2
2-5	General Safety Precautions .....	2-3
2-6	System Safety .....	2-3

## **Chapter 3 Chassis Components**

3-1	Overview .....	3-1
3-2	Components.....	3-1
	Chassis.....	3-1
	Backplane.....	3-1
	Fans .....	3-1
	Mounting Rails .....	3-1
	Power Supply .....	3-2
	Air Shroud .....	3-2
3-3	Where to get Replacement Components.....	3-2

## **Chapter 4 System Interface**

4-1	Overview .....	4-1
4-2	Control Panel Buttons .....	4-2
4-3	Control Panel LEDs .....	4-2
4-4	Drive Carrier LEDs .....	4-4
	SAS/SATA Drives .....	4-4
	SCSI Drives.....	4-4

---



---

## **Chapter 5 Chassis Setup and Maintenance**

5-1	Overview .....	5-1
5-2	Installation and General Maintenance .....	5-1
	Installation .....	5-1
5-3	Removing the Chassis Cover .....	5-2
5-4	Installing Hard Drives .....	5-3
5-5	Installing an Optional Peripheral or Fixed Hard Drive .....	5-6
5-6	Slim DVD-ROM Installation or Replacement .....	5-7
5-7	Installing the Motherboard .....	5-8
	I/O Shield .....	5-8
	Installing the I/O Shield .....	5-8
	Permanent and Optional Standoffs .....	5-9
	PCI Slot Setup .....	5-11
	PCI Slot Setup for SC825U (Universal Output) .....	5-12
5-8	Installing the Air Shroud .....	5-13
	Checking the Server's Air Flow .....	5-14
5-9	System Fans .....	5-15
5-10	Power Supply .....	5-17
	Power Supply Failure .....	5-17
	Replacing the Power Distributor .....	5-19
	Replacing or Installing the Front Port Panel .....	5-20
5-11	Optional Front Bezel .....	5-21

## **Chapter 6 Rack Installation**

6-1	Overview .....	6-1
6-2	Unpacking the System .....	6-1
6-3	Preparing for Setup .....	6-1
	Choosing a Setup Location .....	6-1
	Rack Precautions .....	6-2
	General Server Precautions .....	6-2
	Rack Mounting Considerations .....	6-3
	Ambient Operating Temperature .....	6-3
	Reduced Airflow .....	6-3
	Mechanical Loading .....	6-3
	Circuit Overloading .....	6-3
	Reliable Ground .....	6-3
6-4	Rack Mounting Instructions .....	6-4
	Separating the Sections of the Rack Rails .....	6-4
	Installing the Inner Rail Extension .....	6-5
	Outer Rack Rails .....	6-6

---

***Appendix A SC825 Chassis Cables***

***Appendix B SC825 Power Supply Specifications***

***Appendix C SAS-825TQ Backplane Specifications***



# Chapter 1

## Introduction

### 1-1 Overview

Supermicro's SC825 2U chassis features a unique and highly-optimized design. The chassis is equipped with a high-efficiency power supply.

### 1-2 Shipping List

For the latest shipping lists visit the Supermicro Web site at [www.supermicro.com](http://www.supermicro.com)

SC825 Chassis				
Model	CPU	HDD	I/O	Power Supply
SC825TQ-R740WB	DP/UP	8x SAS/SATA	4xFF 3xLP	740W (Platinum Level Redundant)
SC825TQ-R740UB	DP/UP	8x SAS/SATA	4xFF 3xLP	740W (Platinum Level Redundant)
SC825TQ-R740LPB	DP/UP	8x SAS/SATA	7x LF	740W (Platinum Level Redundant)
SC825TQ-R720LPB	DP/UP	8x SAS/SATA	7x LF	720W (Gold Level Redundant)
SC825TQ-R720UB	DP/UP	8x SAS/SATA	4x FF 3x LP	720W (Gold Level Redundant)
SC825TQ-710LP(V)(B)	DP/UP	8x SAS/ SATA	7x LF	710W
SC825TQ-R700U(V)(B)	DP/UP	8x SAS/SATA	4x FF 3x LP	700W (Redundant)
SC825TQ-R700LPV / SC825TQ-R700LPB	DP/UP	8x SAS/SATA	7x LF	700W (Redundant)
SC825TQ-600LPB	DP/UP	8x SAS/SATA	7x LF	600W
SC825TQ-563UB	DP/UP	8x SAS/SATA	7x LF	560W
SC825TQ-563LPB	DP/UP	8x SAS/SATA	4x FF 3x LP	560W
SC825TQ-560U(V)(B)	DP/UP	8x SAS/SATA	4x FF 3x LP	560W
SC825TQ-560LP(V)(B)	DP/UP	8x SAS/SATA	7x LF	560W

Legend: UP: Single processor. DP: Dual processor. FF: Full-height, full length  
FH: Full-height, half length. LF: Low-profile, full-length. LP: Low-profile.

## 1-3 Chassis Features

The SC825 2U, high-performance chassis includes the following features:

### CPU

Please refer to the motherboard specifications on our Web site for updates on supported processors.

### Hard Drives

The SC825 chassis features eight slots for SAS/SATA drives. These drives are hot-swappable. Once set up correctly, these drives can be removed without powering down the server. In addition, these drives support SES2 (SAS/SATA).

### I/O Expansion slots

The SC825LP chassis model includes seven low-profile, full-length I/O expansion slots. The SC825U/W models include four full-height, full-length slots and three low-profile slots.

### Peripheral Drives

The SC825 chassis supports one optional slim DVD-ROM drive and one optional slim peripheral drive.

### Other Features

Other onboard features are included to promote system health. These include three cooling fans, a convenient power switch, reset button, and five LED indicators.

### SCSI Chassis Models

For information on SCSI chassis models, contact Supermicro's Technical Support department at [www.supermicro.com](http://www.supermicro.com).

## Contacting Supermicro

### Headquarters

Address: Super Micro Computer, Inc.  
980 Rock Ave.  
San Jose, CA 95131 U.S.A.

Tel: +1 (408) 503-8000  
Fax: +1 (408) 503-8008  
Email: [marketing@supermicro.com](mailto:marketing@supermicro.com) (General Information)  
[support@supermicro.com](mailto:support@supermicro.com) (Technical Support)

Web Site: [www.supermicro.com](http://www.supermicro.com)

### Europe

Address: Super Micro Computer B.V.  
Het Sterrenbeeld 28, 5215 ML  
's-Hertogenbosch, The Netherlands

Tel: +31 (0) 73-6400390  
Fax: +31 (0) 73-6416525  
Email: [sales@supermicro.nl](mailto:sales@supermicro.nl) (General Information)  
[support@supermicro.nl](mailto:support@supermicro.nl) (Technical Support)  
[rma@supermicro.nl](mailto:rma@supermicro.nl) (Customer Support)

### Asia-Pacific

Address: Super Micro Computer, Inc.  
4F, No. 232-1, Liancheng Rd.  
Chung-Ho 235, Taipei County  
Taiwan, R.O.C.

Tel: +886-(2) 8226-5990  
Fax: +886-(2) 8226-3991  
Web Site: [www.supermicro.com.tw](http://www.supermicro.com.tw)

Technical Support:  
Email: [support@supermicro.com.tw](mailto:support@supermicro.com.tw)  
Tel: +886-(2)-8226-5990

## 1-5 Returning Merchandise for Service

A receipt or copy of your invoice marked with the date of purchase is required before any warranty service will be rendered. You can obtain service by calling your vendor for a Returned Merchandise Authorization (RMA) number. When returning to the manufacturer, the RMA number should be prominently displayed on the outside of the shipping carton, and mailed prepaid or hand-carried. Shipping and handling charges will be applied for all orders that must be mailed when service is complete.

For faster service, RMA authorizations may be requested online (<http://www.supermicro.com/support/rma/>).

Whenever possible, repack the chassis in the original Supermicro carton, using the original packaging material. If these are no longer available, be sure to pack the chassis securely, using packaging material to surround the chassis so that it does not shift within the carton and become damaged during shipping.

This warranty only covers normal consumer use and does not cover damages incurred in shipping or from failure due to the alteration, misuse, abuse or improper maintenance of products.

During the warranty period, contact your distributor first for any product problems.

## Chapter 2

# System Safety

### 2-1 Overview

This chapter provides a quick setup to get your chassis up and running. Following the steps in order given should enable you to have your chassis set up and operational within a minimal amount of time. This quick setup assumes that you are an experienced technician, familiar with common concepts and terminology.

### 2-2 Warnings and Precautions

You should inspect the box the chassis was shipped in and note if it was damaged in any way. If the chassis itself shows damage, file a damage claim with carrier who delivered your system.

Decide on a suitable location for the rack unit that will hold that chassis. It should be situated in a clean, dust-free area that is well ventilated. Avoid areas where heat, electrical noise and electromagnetic fields are generated.

You will also need it placed near at least one grounded power outlet. When configured, the SC825 chassis includes one power supply. "R" model chassis include redundant power supplies and require two grounded outlets.

### 2-3 Preparing for Setup

The SC825 chassis includes a set of rail assemblies, including mounting brackets and mounting screws you will need to install the systems into the rack. Please read this manual in its entirety before you begin the installation procedure.

## 2-4 Electrical Safety Precautions

Basic electrical safety precautions should be followed to protect yourself from harm and the SC825 from damage:

- Be aware of the locations of the power on/off switch on the chassis as well as the room's emergency power-off switch, disconnection switch or electrical outlet. If an electrical accident occurs, you can then quickly remove power from the system.
- Do not work alone when working with high voltage components.
- Power should always be disconnected from the system when removing or installing main system components, such as the serverboard, memory modules and the DVD-ROM (not necessary for hot-swappable drives). When disconnecting power, you should first power down the system with the operating system and then unplug the power cords from all the power supply modules in the system.
- When working around exposed electrical circuits, another person who is familiar with the power-off controls should be nearby to switch off the power, if necessary.
- Use only one hand when working with powered-on electrical equipment. This is to avoid making a complete circuit, which will cause electrical shock. Use extreme caution when using metal tools, which can easily damage any electrical components or circuit boards they come into contact with.
- Do not use mats designed to decrease electrostatic discharge as protection from electrical shock. Instead, use rubber mats that have been specifically designed as electrical insulators.
- The power supply power cord must include a grounding plug and must be plugged into grounded electrical outlets.
- Serverboard battery: CAUTION - There is a danger of explosion if the onboard battery is installed upside down, which will reverse its polarities. This battery must be replaced only with the same or an equivalent type recommended by the manufacturer. Dispose of used batteries according to the manufacturer's instructions.
- Please handle used batteries carefully. Do not damage the battery in any way; a damaged battery may release hazardous materials into the environment. Do

not discard a used battery in the garbage or a public landfill. Please comply with the regulations set up by your local hazardous waste management agency to dispose of your used battery properly.

- DVD-ROM laser: CAUTION - this server may have come equipped with a DVD-ROM drive. To prevent direct exposure to the laser beam and hazardous radiation exposure, do not open the enclosure or use the unit in any unconventional way.

## 2-5 General Safety Precautions

- Keep the area around the chassis clean and free of clutter.
- Place the chassis top cover and any system components that have been removed away from the system on a table so that they won't accidentally be stepped on.
- While working on the system, do not wear loose clothing such as neckties and unbuttoned shirt sleeves, which can come into contact with electrical circuits or be pulled into a cooling fan.
- Remove any jewelry or metal objects from your body, which are excellent metal conductors that can create short circuits and harm you if they come into contact with printed circuit boards or areas where power is present.
- After accessing the inside of the system, close the system back up and secure it to the rack unit with the retention screws after ensuring that all connections have been made.

## 2-6 System Safety

Electrostatic discharge (ESD) is generated by two objects with different electrical charges coming into contact with each other. An electrical discharge is created to neutralize this difference, which can damage electronic components and printed circuit boards. The following measures are generally sufficient to neutralize this difference before contact is made to protect your equipment from ESD:

- Do not use mats designed to decrease electrostatic discharge as protection from electrical shock. Instead, use rubber mats that have been specifically designed as electrical insulators.
- Use a grounded wrist strap designed to prevent static discharge.

- Keep all components and printed circuit boards (PCBs) in their antistatic bags until ready for use.
- Touch a grounded metal object before removing any board from its antistatic bag.
- Do not let components or PCBs come into contact with your clothing, which may retain a charge even if you are wearing a wrist strap.
- Handle a board by its edges only; do not touch its components, peripheral chips, memory modules or contacts.
- When handling chips or modules, avoid touching their pins.
- Put the serverboard and peripherals back into their antistatic bags when not in use.
- For grounding purposes, make sure your computer chassis provides excellent conductivity between the power supply, the case, the mounting fasteners and the serverboard.



## Chapter 3

# Chassis Components

### 3-1 Overview

This chapter describes the most common components included with your chassis. Some components listed may not be included or may not be compatible with your particular chassis model. For more information, see the installation instructions detailed later in this manual.

### 3-2 Components

#### Chassis

The SC825 chassis includes eight hard drive bays. Hard drives must be purchased separately. For the latest shipping lists, visit our Web site at: <http://www.supermicro.com>.

This chassis supports a 2U backplane, three fans and one or two power supplies. SC825 models come in silver or black.

#### Backplane

Each SC825 chassis comes with a 2U backplane. Depending on our order, you backplane will accept SAS/SATA. For more information regarding compatible backplanes, view the appendices found at the end of this manual. In addition, visit our Web site for the latest information: <http://www.supermicro.com>.

#### Fans

The SC825 chassis supports three system fans. System fans for SC825 chassis are powered from the motherboard. These fans are powered by 4-pin connectors.

#### Mounting Rails

The SC825 can be placed in a rack for secure storage and use. To setup your rack, follow the step-by-step instructions included in this manual.

## **Power Supply**

Each SC825 chassis model includes a high-efficiency power supply rated at 560W (single), 563W (single), 600W (single), 700W (redundant), 710W (single), 720W (redundant) or 740W (Redundant).

## **Air Shroud**

Air shrouds are shields, usually plastic, which conduct the airflow directly to where it is needed. Always use the air shroud included with your chassis.

### **3-3 Where to get Replacement Components**

Although not frequently, you may need replacement parts for your system. To ensure the highest level of professional service and technical support, we strongly recommend purchasing exclusively from our Supermicro Authorized Distributors/System Integrators/Resellers. A list of Supermicro Authorized Distributors/System Integrators/Reseller can be found at: <http://www.supermicro.com>. Click the Where to Buy link.

# Chapter 4

## System Interface

### 4-1 Overview

There are LEDs on the control panel and the drive carriers to keep you constantly informed of the overall status of the system, as well as the activity and health of specific components. Most SC825 models have two buttons on the chassis control panel: a reset button and an on/off switch. This chapter explains the meanings of all LED indicators and the appropriate response you may need to take.

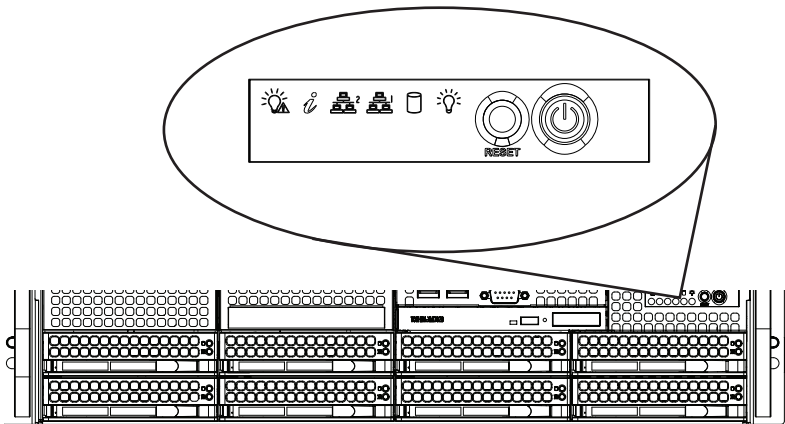
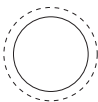

Figure 4-1: SC825 Control Panel

## 4-2 Control Panel Buttons

There are two push-buttons located on the front of the chassis. These are (in order from left to right) a reset button and a power on/off button.



**Reset:** The reset button is used to reboot the system.



**Power:** The main power switch is used to apply or remove power from the power supply to the server system. Turning off system power with this button removes the main power but keeps standby power supplied to the system. Therefore, you must unplug system before servicing.

## 4-3 Control Panel LEDs

The control panel located on the front of the SC825 chassis has six LEDs. These LEDs provide you with critical information related to different parts of the system. This section explains what each LED indicates when illuminated and any corrective action you may need to take.



**Power Failure:** When this LED flashes, it indicates a power failure in the power supply.



Informational LED	
Status	Description
Continuously on and red	An overheat condition has occurred. (This may be caused by cable congestion.)
Blinking red (1Hz)	Fan failure, check for an inoperative fan.
Blinking red (0.25Hz)	Power failure, check for a non-operational power supply.
Solid blue	Local UID has been activated. Use this function to locate the server in a rack mount environment.
Blinking blue (300 mSEC)	Remote UID is on. Use this function to identify the server from a remote location.



**NIC2:** Indicates network activity on GLAN2 when flashing.



**NIC1:** Indicates network activity on GLAN1 when flashing.



**HDD:** Indicates activity in the SAS/SATA drive and/or DVD-ROM drive activity when flashing.



**Power:** Indicates power is being supplied to the system's power supply units. This LED should normally be illuminated when the system is operating.

## 4-4 Drive Carrier LEDs

Your chassis uses SAS/SATA drives.

### SAS/SATA Drives

Each SAS/SATA drive carrier has two LEDs.

- **Green:** Each Serial ATA drive carrier has a green LED. When illuminated, this green LED (on the front of the SATA drive carrier) indicates drive activity. A connection to the SATA backplane enables this LED to blink on and off when that particular drive is being accessed.
- **Red:** The red LED indicates a SAS/SATA drive failure. If one of the SAS/SATA drives fail, you should be notified by your system management software.

### SCSI Drives

For information on SCSI drives contact Supermicro's Technical Support Department at [www.supermicro.com](http://www.supermicro.com).

## Chapter 5

# Chassis Setup and Maintenance

### 5-1 Overview

This chapter covers the steps required to install components and perform maintenance on the chassis. The only tool you will need to install components and perform maintenance is a Phillips screwdriver. Print this page to use as a reference while setting up your chassis.

### 5-2 Installation and General Maintenance

#### Installation

- Removing the Chassis Cover
- Installing Hard Drives
- Installing an Optional Peripheral Drive or Fixed Hard Drive
- Slim DVD ROM Replacement or Installation
- Installing the Motherboard (includes I/O Slot Setup)
- Installing the Air Shroud

#### General Maintenance

- System Fans
- Replacing the Power Supply
- Optional Front Bezel



Review the warnings and precautions listed in the manual before setting up or servicing this chassis. These include information in Chapter 2: System Safety and the warning/precautions listed in the setup instructions.

## 5-3 Removing the Chassis Cover

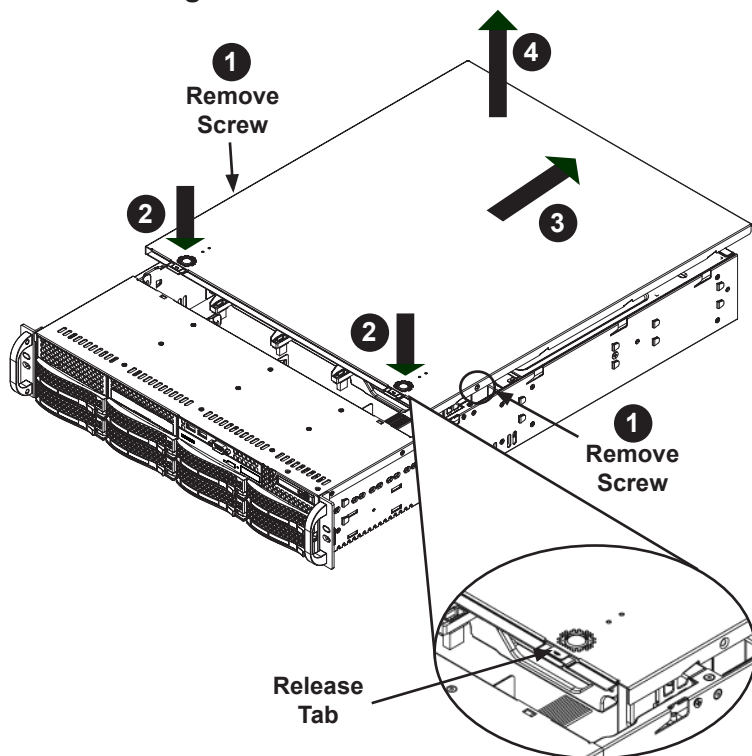

Figure 5-1: Removing the Chassis Cover

### *Removing the Chassis Cover*

1. Remove the two screws on each side of the cover, which secure the cover to the chassis.
2. Press the release tabs to remove the cover from the locked position. Press both tabs at the same time.
3. Once the top cover is released from the locked position, slide the cover toward the rear of the chassis.
4. Lift the cover off the chassis.



Warning: Except for short periods of time, do NOT operate the server without the cover in place. The chassis cover must be in place to allow proper airflow and prevent overheating.



## 5-4 Installing Hard Drives

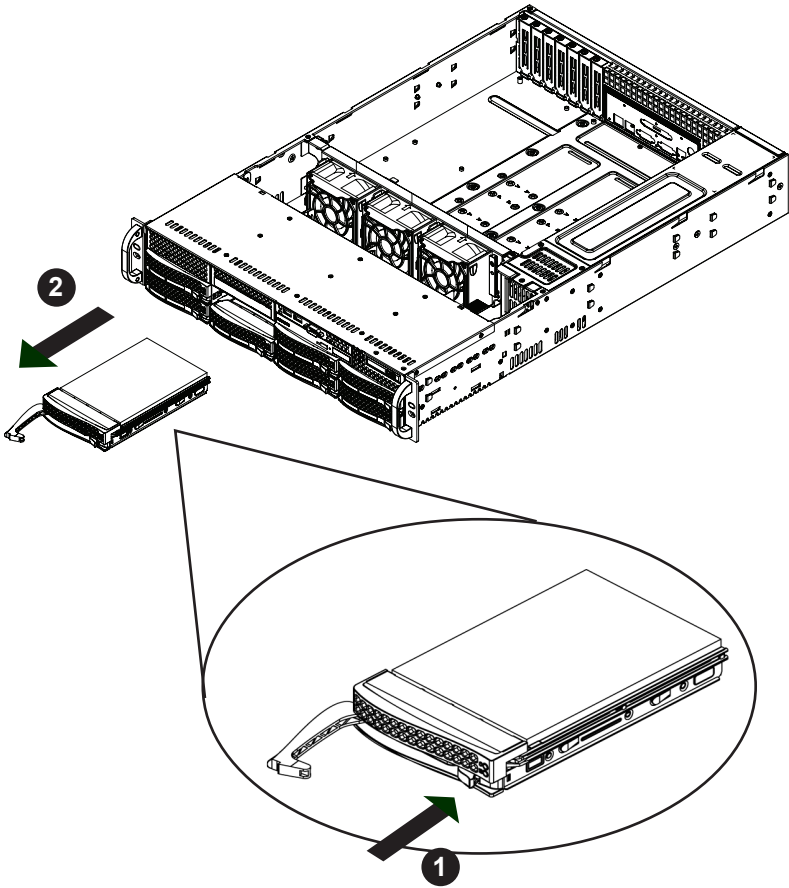
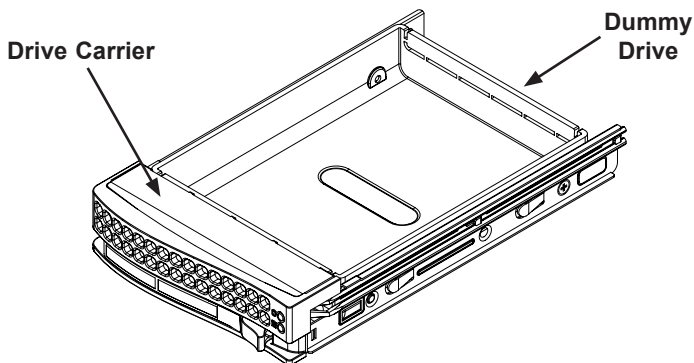

Figure 5-2: Removing Hard Drive

### *Removing Hard Drive Trays from the Chassis*

1. Press the release button on the drive carrier. This extends the drive carrier handle.
2. Use the handle to pull the drive out of the chassis.

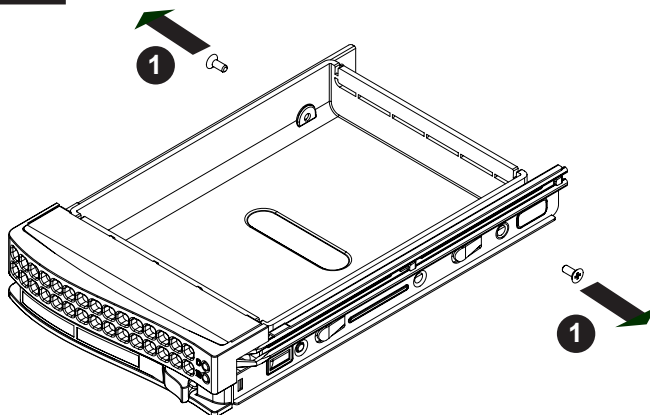

**Figure 5-3: Chassis Drive Carrier**

The drives are mounted in drive carriers to simplify their installation and removal from the chassis. These carriers also help promote proper airflow for the drive bays.



Warning: Except for short periods of time (swapping hard drives), do not operate the server with the hard drives removed from the bays.



**Figure 5-4: Removing Dummy Drive from Carrier**

#### ***Installing a Hard Drive to the Hard Drive Carrier***

1. Remove the screws securing the dummy drive to the carrier.
2. Remove the dummy drive from the carrier.

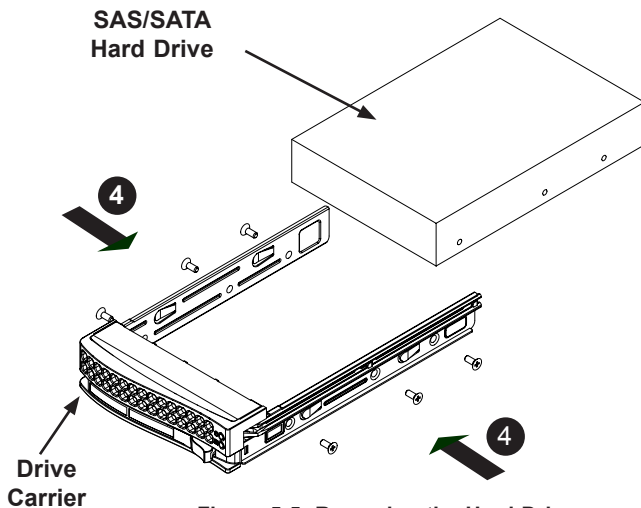

**Figure 5-5: Removing the Hard Drive**

3. Install a new drive into the carrier with the printed circuit board side facing down so that the mounting holes align with those in the carrier.
4. Secure the hard drive by tightening all six screws.
5. Insert the drive carrier into the chassis bay, making sure that the drive carrier handle is completely closed.

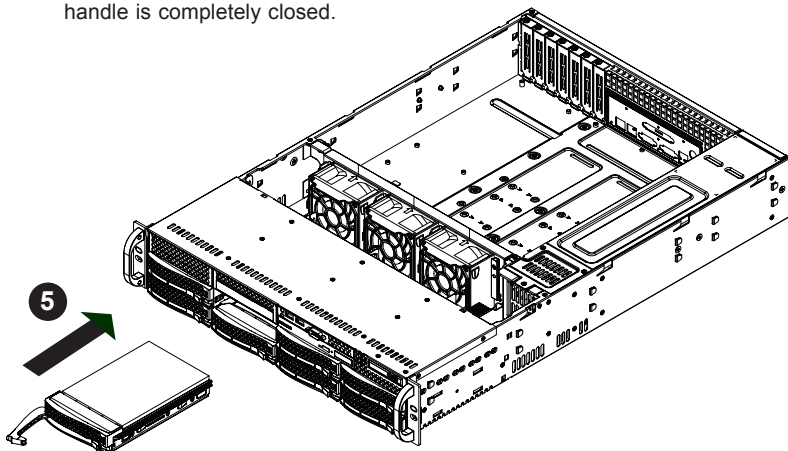

**Figure 5-6: Installing the Hard Drive**



**Warning!** Enterprise level hard disk drives are recommended for use in Supermicro chassis and servers.

## 5-5 Installing an Optional Peripheral or Fixed Hard Drive

The SC825 chassis models include two open slots for an optional peripheral drive, and/or hard disk drive(s). To utilize these slots, the dummy drive and the slot cover must be removed.

### ***Removing and Installing the Dummy Drive, Peripheral Drive or Hard Disk Drive***

1. Disconnect the chassis from any power source.
2. Press the release tab.
3. Push against the back of the dummy drive, sliding the dummy drive and slot cover forward, out through the front of the chassis.
4. Insert the drive into rear of the open slot and connect the wiring.

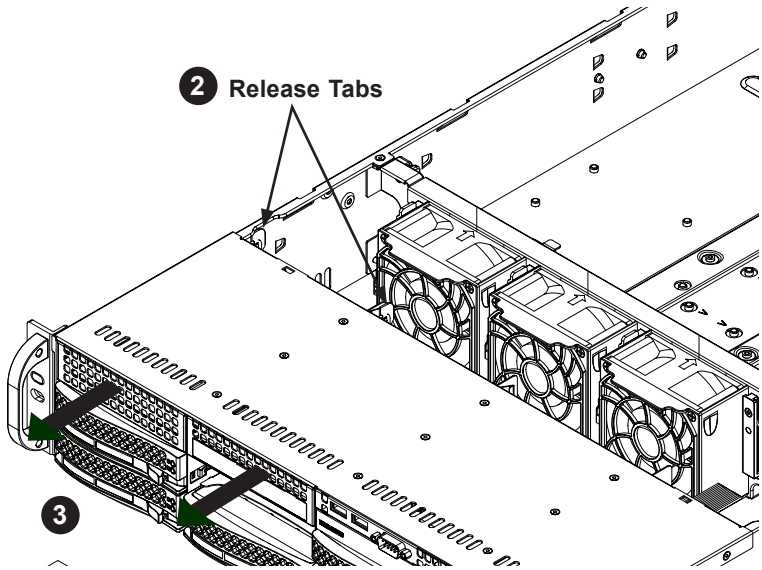

Figure 5-7: Removing the Dummy Drive and Slot Cover

## 5-6 Slim DVD-ROM Installation or Replacement

### *Installing or Replacing a Slim DVD-ROM Drive*

1. Power down the system and if necessary, remove the server from the rack.
2. Remove the chassis cover.
3. Unplug the drives power and data cables from the motherboard and/or back-plane.
4. **If you are adding a new DVD-ROM drive:** Remove the mini-bezel (grate) from the drive bay. The bezel can be removed by pulling out the hard drive beneath the DVD-ROM drive bay, then pulling the mini-bezel forward.  
**If you are replacing a drive:** Locate the locking tab at the rear (left hand side when viewed from the front) of the DVD-ROM drive. Push the tab toward the drive and push the drive unit out the front of the chassis.
5. Insert the new drive unit in the slot until the tab locks in place.
6. Reconnect the data and power cables.
7. Replace the chassis cover (replace the server in the rack, if necessary) and power up the system.

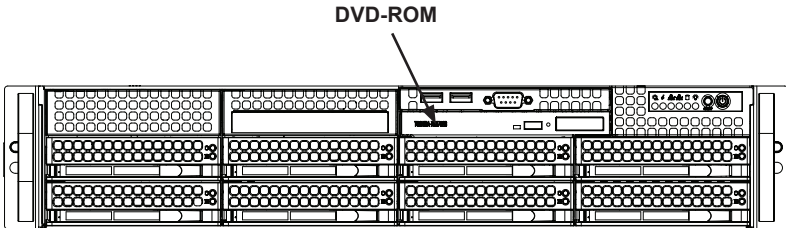

Figure 5-8: Slim DVD-ROM Location

## 5-7 Installing the Motherboard

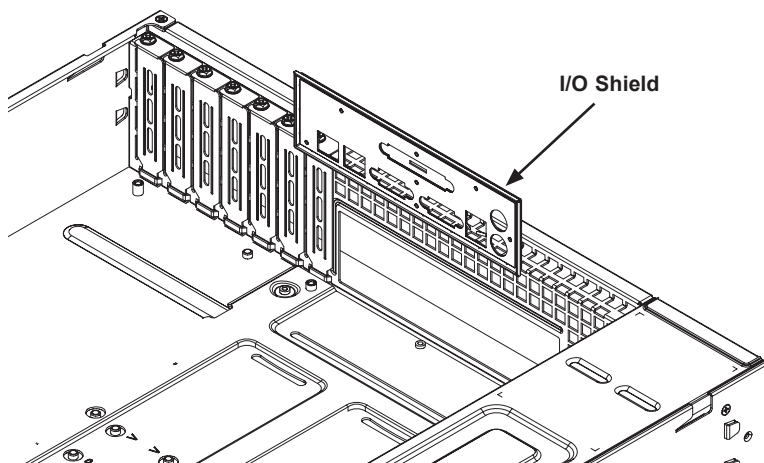

Figure 5-9: I/O Shield Placement

### I/O Shield

The I/O shield holds the motherboard ports in place. Install the I/O shield before you install the motherboard.

### Installing the I/O Shield

#### *Installing the I/O Shield*

1. Review the documentation that came with your motherboard. Become familiar with component placement, requirements, and precautions.
2. Open the chassis cover.
3. With the illustrations facing the outside of the chassis, place the shield into the space provided and push the shield outward until it clicks into the locked position.
4. Once installed, the chassis' rear window will hold the I/O shield in place.

## **Permanent and Optional Standoffs**

Standoffs prevent short circuits by securing space between the motherboard and the chassis surface. The SC825 chassis includes permanent standoffs in locations used by most motherboards. These standoffs accept the rounded Phillips head screws included in the SC825 accessories packaging.

Some motherboards require additional screws for heatsinks, general components and/or non-standard security. Optional standoffs are included to these motherboards. To use an optional standoff, you must place the hexagonal screw through the bottom the chassis and secure the screw with the hexagon nut (rounded side up).

### ***Installing the Motherboard***

1. Review the documentation that came with your motherboard. Become familiar with component placement, requirements, precautions, and cable connections.
2. Open the chassis cover.
3. As required by your motherboard, install standoffs in any areas that do not have a permanent standoff. To do this:
  - A. Place a hexagonal standoff screw through the bottom the chassis.
  - B. Secure the screw with the hex nut (rounded side up).
4. Lay the motherboard on the chassis aligning the permanent and optional standoffs
5. Secure the motherboard to the chassis using the rounded, Phillips head screws. Do not exceed eight pounds of torque when tightening down the motherboard.
6. Secure the CPU(s), heatsinks, and other components to the motherboard as described in the motherboard documentation.
7. Connect the cables between the motherboard, backplane, chassis, front panel, and power supply, as needed. Also, the fans may be temporarily removed to allow access to the backplane ports.

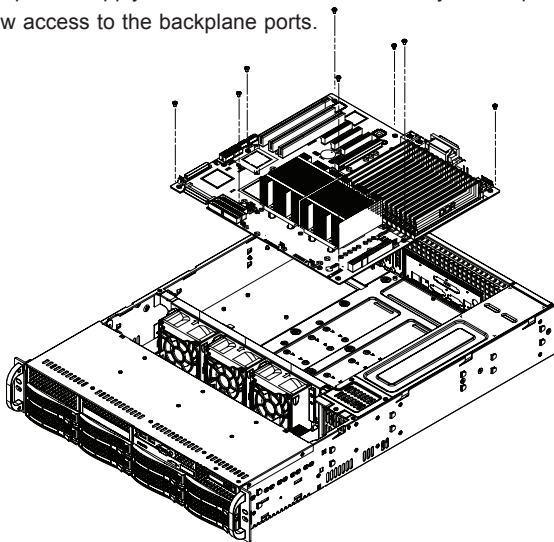

**Figure 5-10: Chassis Standoffs**



## PCI Slot Setup

The SC825 chassis includes PCI slots for expansion cards. The number of cards you can use depends upon your chassis model.

**SC825LP:** Includes seven low-profile, full-length PCI slots.

**SC825U and SC825W:** Includes four full-height, full-length and three low-profile PCI slots which support user-defined universal expansion cards.

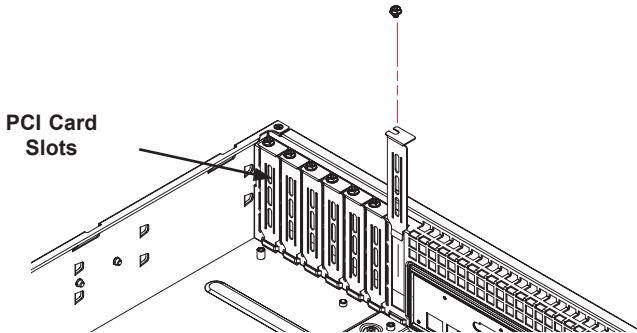

Figure 5-11: SC825 LP model

### *Installing Expansion cards in SC825LP (Low-Profile) Chassis*

1. Disconnect the power supply, lay the chassis on a flat surface, and open the chassis cover.
2. Remove the screw holding the cover in place for each low-profile PCI card slot you want to use. Keep this screw for later use.
3. Connect the expansion cards to the mother board.
4. Secure each card to the chassis using the card's L-bracket and the screw previously removed.

## **PCI Slot Setup for SC825U (Universal Output)**

The SC825U chassis accepts a slightly smaller L-shaped motherboard to allow for a universal expansion card. This universal output card allows the systems to accept SAS, IB, Ethernet, and other types of connections.

### ***Installing a Riser Card in the SC825U Chassis:***

1. Disconnect the power supply, lay the chassis on a flat surface, and open the chassis cover.
2. Plug the riser card into the designated riser card slot on the motherboard. Riser cards provide horizontal slots for the expansion cards.
3. Secure the riser card to the riser card bracket with chassis using the screws provided.

The SC825U chassis accepts four full-height, full-length expansion cards and three low-profile expansion cards.

### ***Installing Expansion Cards in the SC825U Chassis***

1. Disconnect the power supply, lay the chassis on a flat surface, and open the chassis cover.
2. Plug the expansion cards into the appropriate slots on the riser cards, beginning with the lower slots first and working towards the upper slots.
3. If you are installing low-profile expansion cards, remove the chassis air shroud to provide more work space.
4. Secure the expansion card to the chassis PCI slot to complete the installation.

## 5-8 Installing the Air Shroud

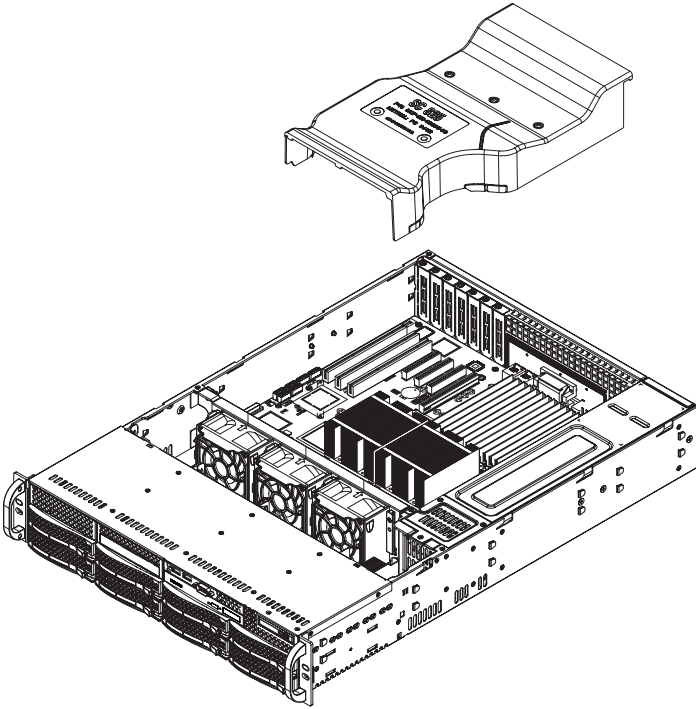

**Figure 5-12: Air Shroud for SC825LP Chassis**

Air shrouds concentrate airflow to maximize cooling efficiency. The SC825 chassis air shroud does not require screws for installation.

### ***Installing the Air Shroud***

1. Confirm that your air shroud matches your chassis model.
2. Place the air shroud in the chassis. The air shroud fits behind the two fans closest to the power supply.

## Checking the Server's Air Flow

### *Checking the Air Flow*

1. Make sure there are no objects to obstruct airflow in and out of the server. In addition, if you are using a front bezel, make sure the bezel's filter is cleaned periodically.
2. Do not operate the server without drives or drive trays in the drive bays. Supermicro recommends enterprise level hard disk drives for the best reliability and performance.
3. Make sure no wires or foreign objects obstruct air flow through the chassis. Pull all excess cabling out of the airflow path or use shorter cables.

## 5-9 System Fans

Three heavy-duty fans provide the best cooling for the system. These fans circulate air through the chassis as a means of lowering the system's internal temperature.

System fans are hot-swappable. This means that there is no need to power-down the system when replacing a system fan. Never run the system for an extended period of time without all of the required system fans in place and functioning properly.

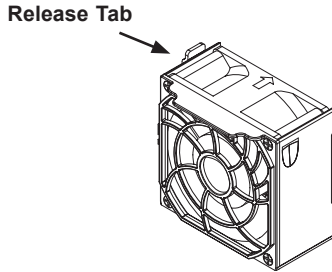

**Figure 5-13: System Fan**

### ***Replacing a System Fan***

1. If necessary, open the chassis top cover while the power is running to determine which fan has failed. (Never run the server for an extended period of time with the chassis top cover open.)
2. Press the fan release tab to lift the failed fan from the chassis and pull it completely from the chassis.
3. Place the new fan into the vacant space in the housing while making sure the arrows on the top of the fan (indicating air direction) point inward toward the system's motherboard.
4. Check that the fan is working properly before replacing the chassis top cover.

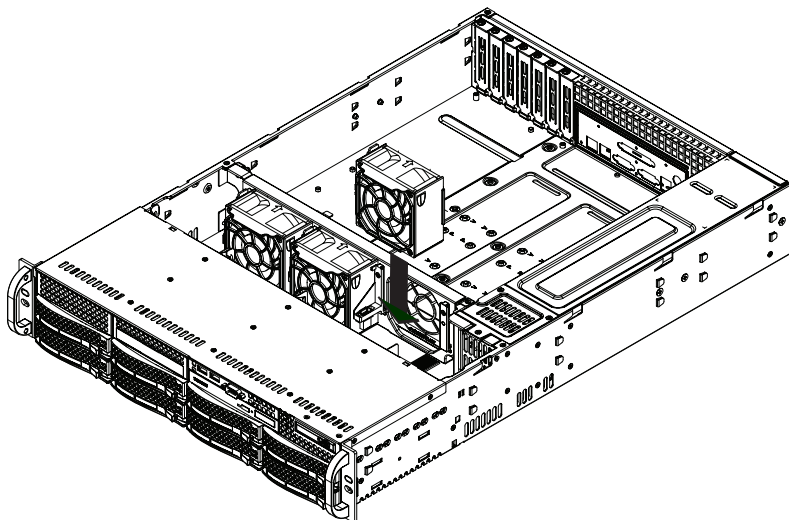

**Figure 5-14: Placing the System Fan**

## 5-10 Power Supply

Depending on your chassis model, the SC825 chassis has a 560W (single), 563W (single), 600W (single), 700W (redundant), 710W (single), 720W (redundant) or 740W (redundant) Watt power supply. Power supplies are auto-switching capable. This enables it to automatically sense and operate at a 100v to 240v input voltage. An amber light will be illuminated on the power supply when the power is off. An illuminated green light indicates that the power supply is operating.

### Power Supply Failure

SC825 chassis models have either one or two (redundant) power supplies. In the unlikely event that the power supply unit fails, if you have a single power supply, the system will shut down and you will need to replace the power supply unit. SC825 chassis models which include a redundant power supply, will allow for the power supply to be replaced without powering down the system. Replacement units can be ordered directly from Supermicro at [www.supermicro.com](http://www.supermicro.com).

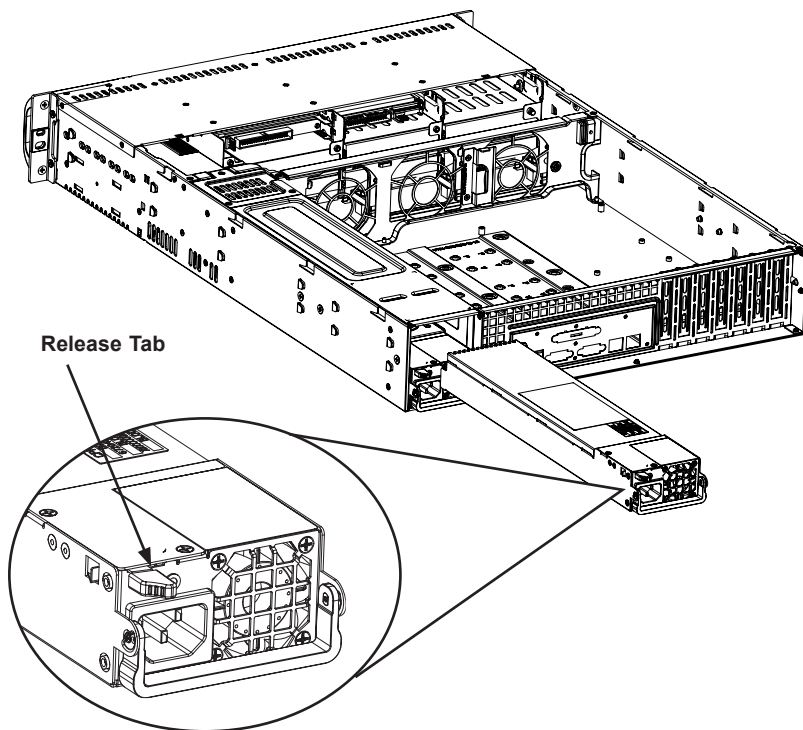
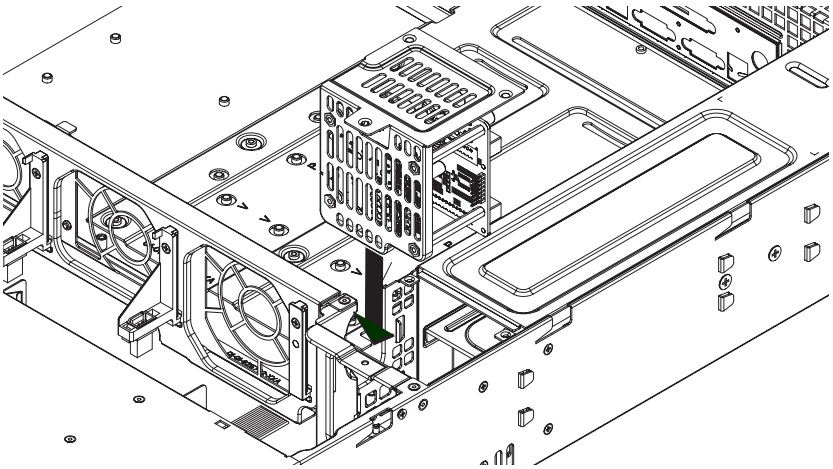

**Figure 5-15: Removing the Power Supply**

### ***Replacing the Power Supply***

1. If your chassis includes a redundant power supply (at least two power modules), you can leave the server running and remove only one power supply. If your server has a single power supply, you must power-down the server and unplug the power cord before replacing the power supply.
2. Push the release tab (on the back of the power supply) as illustrated.
3. Pull the power supply out using the handle provided.
4. Replace the failed power module with the same model.
5. Push the new power supply module into the power bay until you hear a click.
6. Plug the AC power cord back into the module and power up the server.





**Figure 5-16: Replacing the Power Distributor**

## Replacing the Power Distributor

Redundant server chassis require a power distributor. The power distributor provides failover and power supply redundancy. In the unlikely event you must replace the power distributor, do the following:

1. Power down the server and remove the plug from the wall socket or power strip.
2. Remove all cable connections to the power supply from the motherboard, backplane, and other components. Also, remove both power supplies.
3. Locate the power distributor between the power supply and the fan row.
4. Remove the screws securing the power supply.
5. Gently pull the power distributor from the chassis. Gently guide all the cables through the power distributor housing.
6. Slide the new power distributor module into the power distributor housing. Make that you slide the cables through the bottom of the housing.
7. Reconnect all the power cables, replace the power supply, and insert the plug into the wall.

## **Replacing or Installing the Front Port Panel**

### ***Replace or Install the Front Port Panel***

1. Power down the system and unplug the chassis power cord from the outlet.
2. Remove the chassis top cover.
3. Disconnect the power and data cables from the front port panel to other chassis components including the motherboard and backplane.
4. Remove the old port panel by depressing the release tab, then pulling the unit out of the chassis.
5. Insert the new front port panel unit in the slot until the tab locks into place.
6. Connect the data and power cables to the backplane and motherboard.

For more information, see the backplane appendices in this manual.

## 5-11 Optional Front Bezel

The SC825 chassis supports an optional full-face locking front bezel for added security. The front bezel is not included with the SC825 chassis, but can be ordered separately by visiting the Supermicro Web site at [www.supermicro.com](http://www.supermicro.com), clicking on the Where to Buy link and entering part number MCP-210-82503-0B.

## Notes

## Chapter 6

# Rack Installation

### 6-1 Overview

This chapter provides a quick setup to get your chassis up and running. Following these steps in the order given should enable you to have the system operational within a minimum amount of time.

### 6-2 Unpacking the System

You should inspect the box the chassis was shipped in and note if it was damaged in any way. If the chassis itself shows damage you should file a damage claim with the carrier who delivered it.

Decide on a suitable location for the rack unit that will hold your chassis. It should be situated in a clean, dust-free area that is well ventilated. Avoid areas where heat, electrical noise and electromagnetic fields are generated. You will also need it placed near a grounded power outlet. Be sure to read the Rack and Server Precautions in the next section.

### 6-3 Preparing for Setup

The box your chassis was shipped in should include two sets of rail assemblies, two rail mounting brackets and the mounting screws you will need to install the system into the rack. Please read this section in its entirety before you begin the installation procedure outlined in the sections that follow.

#### Choosing a Setup Location

- Leave enough clearance in front of the rack to enable you to open the front door completely (~25 inches).
- Leave approximately 30 inches of clearance in the back of the rack to allow for sufficient airflow and ease in servicing.
- This product is for installation only in a Restricted Access Location (dedicated equipment rooms, service closets and the like).



## Warnings and Precautions!



### Rack Precautions

- Ensure that the leveling jacks on the bottom of the rack are fully extended to the floor with the full weight of the rack resting on them.
- In single rack installation, stabilizers should be attached to the rack.
- In multiple rack installations, the racks should be coupled together.
- Always make sure the rack is stable before extending a component from the rack.
- You should extend only one component at a time, extending two or more simultaneously may cause the rack to become unstable.

### General Server Precautions

- Review the electrical and general safety precautions that came with the components you are adding to your chassis.
- Determine the placement of each component in the rack *before* you install the rails.
- Install the heaviest server components on the bottom of the rack first, and then work up.
- Use a regulating uninterruptible power supply (UPS) to protect the server from power surges, voltage spikes and to keep your system operating in case of a power failure.
- Allow the hot plug hard drives and power supply modules to cool before touching them.
- Always keep the rack's front door and all panels and components on the servers closed when not servicing to maintain proper cooling.

## **Rack Mounting Considerations**

### ***Ambient Operating Temperature***

If installed in a closed or multi-unit rack assembly, the ambient operating temperature of the rack environment may be greater than the ambient temperature of the room. Consideration should be given to installing the equipment in an environment compatible with the manufacturer's maximum rated ambient temperature ( $T_{mra}$ ).

### ***Reduced Airflow***

Equipment should be mounted into a rack so that the amount of airflow required for safe operation is not compromised.

### ***Mechanical Loading***

Equipment should be mounted into a rack so that a hazardous condition does not arise due to uneven mechanical loading.

### ***Circuit Overloading***

Consideration should be given to the connection of the equipment to the power supply circuitry and the effect that any possible overloading of circuits might have on overcurrent protection and power supply wiring. Appropriate consideration of equipment nameplate ratings should be used when addressing this concern.

### ***Reliable Ground***

A reliable ground must be maintained at all times. To ensure this, the rack itself should be grounded. Particular attention should be given to power supply connections other than the direct connections to the branch circuit, for example the use of power strips and other devices.

## 6-4 Rack Mounting Instructions

This section provides information on installing the SC825 chassis into a rack unit with the quick-release rails provided. There are a variety of rack units on the market, which may mean the assembly procedure will differ slightly. You should also refer to the installation instructions that came with the rack unit you are using.

**NOTE:** This rail will fit a rack between 26.5" and 36.4" deep.

### Separating the Sections of the Rack Rails

The chassis package includes two rail assemblies in the rack mounting kit. Each assembly consists of two sections: an inner fixed chassis rail that secures directly to the server chassis and an outer fixed rack rail that secures directly to the rack itself.

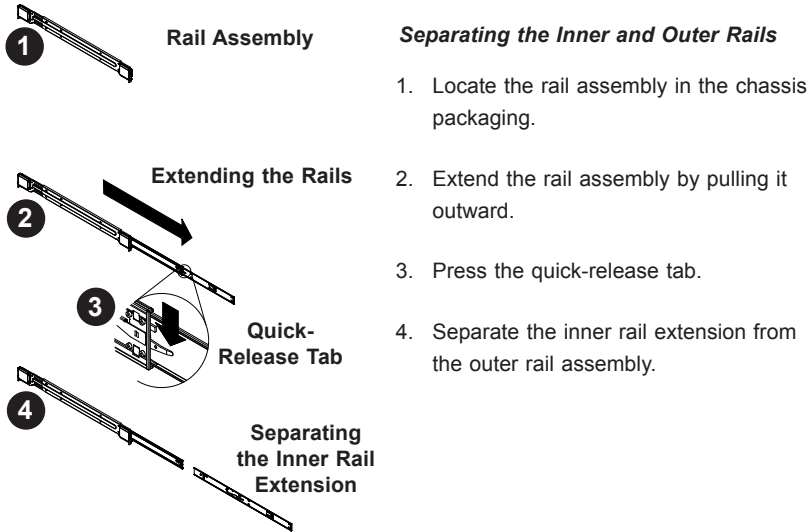

#### *Separating the Inner and Outer Rails*

1. Locate the rail assembly in the chassis packaging.
2. Extend the rail assembly by pulling it outward.
3. Press the quick-release tab.
4. Separate the inner rail extension from the outer rail assembly.

Figure 6-1: Separating the Rack Rails



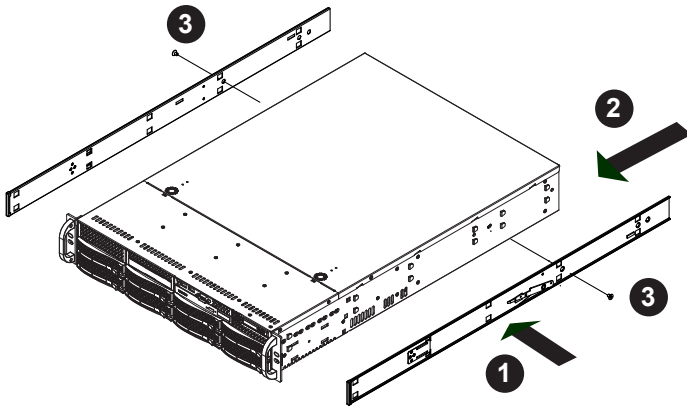

Figure 6-2: Installing the Inner Rail Extensions

### Installing the Inner Rail Extension

The SC825 chassis includes a set of inner rails in two sections: inner rails and inner rail extensions. The inner rails are pre-attached to the chassis, and do not interfere with normal use of the chassis if you decide not to use a server rack. The inner rail extension is attached to the inner rail to mount the chassis in the rack.

#### *Installing the Inner Rails*

1. Place the inner rail extensions on the side of the chassis aligning the hooks of the chassis with the rail extension holes. Make sure the extension faces "outward" just like the pre-attached inner rail.
2. Slide the extension toward the front of the chassis.
3. Optional: Secure the chassis with two screws as illustrated. Repeat steps for the other inner rail extension.

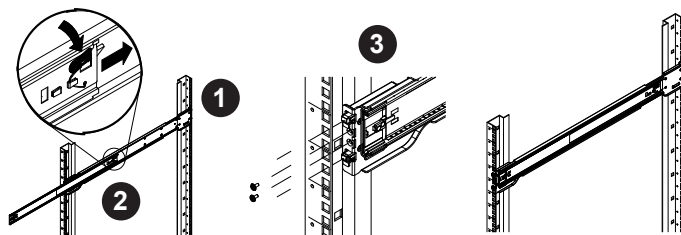

**Figure 6-3: Assembling the Outer Rails**

## Outer Rack Rails

Outer rails attach to the rack and hold the chassis in place. The outer rails for the SC825 chassis extend between 26.5 inches and 36.4 inches.

### *Installing the Outer Rails to the Rack*

1. Secure the back end of the outer rail to the rack, using the screws provided.
2. Press the button where the two outer rails are joined to retract the smaller outer rail.
3. Hang the hooks of the rails onto the rack holes and if desired, use screws to secure the front of the outer rail onto the rack.
4. Repeat steps 1-3 for the remaining outer rail.

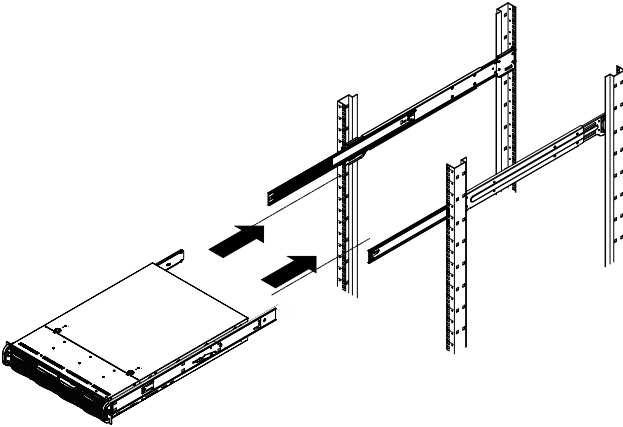

**Figure 6-4: Installing the Chassis into the Rack**

***Installing the Chassis into a Rack***

1. Extend the outer rails as illustrated above.
2. Align the inner rails of the chassis with the outer rails on the rack.
3. Slide the inner rails into the outer rails, keeping the pressure even on both sides. When the chassis has been pushed completely into the rack, it should click into the locked position.
4. Optional screws may be used to secure the front of the chassis to the rack.

## Notes

## Appendix A

### SC825 Chassis Cables

#### A-1 Overview

This appendix lists supported cables for your chassis system. It only includes the most commonly used components and configurations. For more compatible cables, refer to the manufacturer of the motherboard you are using and our Web site at: [www.supermicro.com](http://www.supermicro.com).

#### A-2 Cables Included with SC825TQ Chassis

The following chart contains the basic set of cables included with SC825TQ chassis models. Some models may include additional cables. Visit the Supermicro Web site at [www.supermicro.com](http://www.supermicro.com) for information specific to your chassis model.

SC825TQ			
Part #	Type	Length	Description
CBL-0157L	Cable	40 cm	8-pin to 8-pin ribbon cable for SGPIO, PB free
CBL-0071L	Cable	30"	16- pin to 16-pin ribbon cable for control panel
CBL-0179L	Cable	70 cm	SATA cable
-	Cable	6'	Two regional power cords
CBL-0180L-01	SATA Cable	varies	Set for four SATA round cables. Lengths vary, 70, 59, 48, and 38cm to minimize airflow interference.
CBL-0044L	SATA Cable	30"	16-pin to 16-pin ribbon cable for the control panel.

## A-5 Compatible Cables

These cables are compatible with the SC825 Chassis.

### Alternate SAS/SATA Cables

Some compatible motherboards have different connectors. If your motherboard has only one SAS connector that the SAS/SATA cables must share, use one of the following cables. These cables must be purchased separately.

**Cable Name:** SAS Cable

**Quantity:** 1

**Part #:** CBL-0175L

**Alt. Name:** "Big Four"

**Description:** This cable has one SFF-8484 (32-pin) connector on one end and four SAS connectors with seven pins on each connector, at the other end. This cable connects from the host (motherboard or other controller) to the backplane SAS hard drive port.

**Cable Name:** SAS Cable

**Quantity:** 1

**Part #:** CBL-0116L

**Alt. Name:** iPass or "Small Four"

**Description:** This cable has one iPass (SFF-8087/Mini-SAS) connector (36-pins) at one end and four SAS connectors on the other. This cable connects from the host motherboard or other controller, to the backplane SAS hard drive port.

## Extending Power Supply Cables

Although Supermicro chassis are designed to be efficient and cost-effective, some compatible motherboards have power connectors located in different areas.

To use these motherboards you may have to extend the power cables to the motherboards. To do this, use the following chart as a guide.

<b>Power Cable Extenders</b>		
<b>Number of Pins</b>	<b>Cable Part #</b>	<b>Length</b>
24-pin	CBL-0042L	7.9" (20 cm)
20-pin	CBL-0059L	7.9" (20 cm)
8-pin	CBL-0062L	7.9" (20 cm)
4-pin	CBL-0060L	7.9" (20 cm)

## Notes



## Appendix B

### SC825 Power Supply Specifications

This appendix lists power supply specifications for your chassis system.

SC825 Series				
	560W	563W	600W	R700W (Redundant)
<b>MFR Part #</b>	PWS-561-1H20	PWS-563-1H20	PWS-605P-1H	PWS-702A-IR
<b>Rated AC Voltage</b>	100 - 240V 50 - 60Hz 8.5 - 4 Amp	100-240 V 50-60 Hz 7.5 Amp max	100-240 V 50-60 Hz 7.5 Amp max	100 - 240V 60-50Hz 10 - 4 Amp
<b>+5V standby</b>	3 Amp	3 Amp	3 Amp	4 Amp
<b>+12V</b>	43.6 Amp	46 Amp @ 100-180V; 49 Amp @ 180-240V	49 Amp	57 Amp
<b>+5V</b>	25 Amp	18 Amp	18 Amp	24 Amp
<b>+3.3V</b>	21 Amp	15 Amp	15 Amp	21 Amp
<b>-12V</b>	0.6 Amp	0.5 Amp	0.5	0.6 Amp

SC825 Series			
	710W DC-DC Power Supply	R720W (Redundant)	740W
<b>MFR Part #</b>	PWS-711-1R	PWS-721P-1R	PWS-741P-1R
<b>Rated AC Voltage</b>	---	---	100-240 V, 50-60 Hz 9-3.5 Amp
<b>AC Input</b>	---	100-240 V, 50-60 Hz, 4-9 Amp	---
<b>DC Input Voltage</b>	Voltage Range = -36V to -75V (24A - 11A) Nominal Voltage = -48V	---	---
<b>DC Output</b>	---	3 Amp @ +5V standby 59 Amp @ +12V	4 Amp @ +5V standby 61.7 Amp @ +12V
<b>+5V standby</b>	4 Amp	---	---
<b>+12V</b>	59 Amp	---	---
<b>+5V</b>	30 Amp	45 Amp	---
<b>+3.3V</b>	20 Amp	24 Amp	---
<b>-12V</b>	0.6 Amp	0.6 Amp	---

## Appendix C

### SAS-825TQ Backplane Specifications

To avoid personal injury and property damage, carefully follow all the safety steps listed below when accessing your system or handling the components.

#### C-1 ESD Safety Guidelines

*Electrostatic Discharge (ESD) can damage electronic components. To prevent damage to your system, it is important to handle it very carefully. The following measures are generally sufficient to protect your equipment from ESD.*

- Use a grounded wrist strap designed to prevent static discharge.
- Touch a grounded metal object before removing a component from the antistatic bag.
- Handle the backplane by its edges only; do not touch its components, peripheral chips, memory modules or gold contacts.
- When handling chips or modules, avoid touching their pins.
- Put the card and peripherals back into their antistatic bags when not in use.

#### C-2 General Safety Guidelines

- Always disconnect power cables before installing or removing any components from the computer, including the SAS-825TQ backplane.
- Disconnect the power cable before installing or removing any cables from the SAS-825TQ backplane.
- Make sure that the SAS-825TQ backplane is securely and properly installed on the motherboard to prevent damage to the system due to power shortage.

### **C-3 An Important Note to Users**

All images and layouts shown in this user's guide are based upon the latest PCB Revision available at the time of publishing. The card you have received may or may not look exactly the same as the graphics shown in this manual.

### **C-4 Introduction to the SAS-825TQ Backplane**

The SAS-825TQ backplane has been designed to utilize the most up-to-date technology available, providing your system with reliable, high-quality performance.

This manual reflects SAS-825TQ Revision 2.0, the most current release available at the time of publication. Always refer to the Supermicro Web site at [www.supermicro.com](http://www.supermicro.com) for the latest updates, compatible parts and supported configurations.

## C-5 Front Connectors and SAS Ports

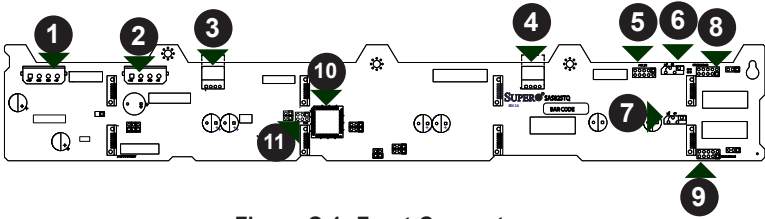

Figure C-1: Front Connectors

### Front Connectors

1. 4-pin power connector: JP13
2. 4-pin power connector: JP10
3. CD-ROM/floppy connector: JP18
4. CD-ROM/floppy connector: JP17
5. Activity in LED header: JP26
6. I<sup>2</sup>C Connector #2: JP45
7. I<sup>2</sup>C Connector #1: JP44
8. Sideband Connector #2: JP52
9. Sideband Connector #1: JP51
10. MG9072 chip
11. Upgrade Header: JP46

### SAS Ports

12. SAS Port #0
13. SAS Port #1
14. SAS Port #2
15. SAS Port #3
16. SAS Port #4
17. SAS Port #5
18. SAS Port #6
19. SAS Port #7

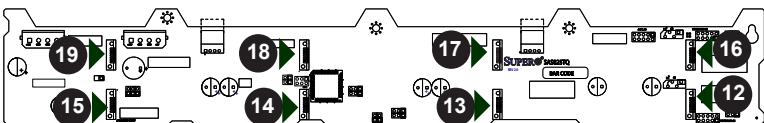

Figure C-2: Front SAS Ports

## C-6 Front Connector and Pin Definitions

### #1 and #2 Backplane Main Power Connectors

The 4-pin connectors, designated JP10, and JP13 provide power to the backplane. See the table on the right for pin definitions.

Backplane Main Power 4-Pin Connector	
Pin#	Definition
1	+12V
2 and 3	Ground
4	+5V

### #3 and #4 CD-ROM/Floppy Pin Connectors

Pin connectors designated J17 and J18, provide power to the CD-ROM and floppy drives. See the table on the right for pin definitions.

CD-ROM/FDD Power 4-Pin Connector	
Pin#	Definition
1	+5V
2 and 3	Ground
4	+12V

### #5 Activity LED Headers

The activity LED header, designated JP26 is used to indicate the activity status of each SAS drive. The activity LED header is located on the front panel. For the activity lead header to work properly, connect to it using a 10-pin LED cable. This is only used when the activity LED is not supported by the hard drive.

SAS Activity LED Header Pin Definitions			
Pin #	Definition	Pin #	Definition
1	ACT IN#0	6	ACT IN#4
2	ACT IN#1	7	ACT IN#5
3	ACT IN#2	8	ACT IN#6
4	ACT IN#3	9	ACT IN#7
5	Ground	10	Empty

### #6 and #7 I<sup>2</sup>C Connectors

The I<sup>2</sup>C Connectors, designated JP44 and JP45, are used to monitor the HDD activity and status. See the table on the right for pin definitions.

I <sup>2</sup> C Connector Pin Definitions	
Pin#	Definition
1	Data
2	Ground
3	Clock
4	No Connection

**#8 and #9 Sideband Headers**

The sideband headers are designated JP51 and JP52. For SES-2 to work properly, you must connect an 8-pin sideband cable. See the table to the right for pin definitions.

Sideband Headers			
Pin #	Definition	Pin #	Definition
2	SGPIO: SDIN; I <sup>2</sup> C: Backplane Addressing	1	Controller ID (SB6)
4	SGPIO: SDOUT; I <sup>2</sup> C: Reset	3	GND (SB2)
6	GND (SB3)	5	SGPIO: SLOAD; I <sup>2</sup> C: SDA
8	Backplane ID (SB7)	7	SGPIO: SCLOCK; I <sup>2</sup> C: SCL
10	No Connec- tion	9	No Connec- tion

**#10 MG9072 Chip**

The MG9072 is an enclosure management chip that supports the SES-2 controller and SES-2 protocols.

**#11 Upgrade Header**

The upgrade header is designated JP46 and is used for manufacturing purposes only.

**#12 to #19 SAS Ports**

The SAS ports are used to connect the SAS drive cables. The 8 ports are designated #0 - #7. Each port is also compatible with SATA drives.

## C-7 Front Jumper Locations and Pin Definitions

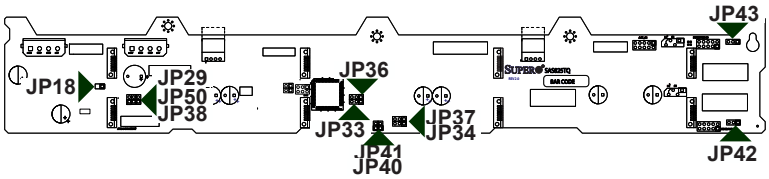
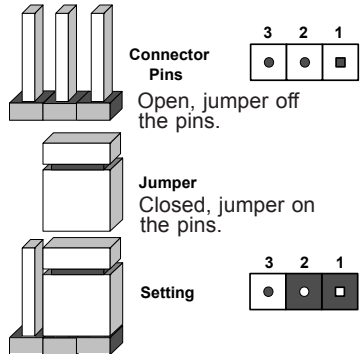

Figure C-3: Front Jumpers

### Explanation of Jumpers

To modify the operation of the backplane, jumpers can be used to choose between optional settings. Jumpers create shorts between two pins to change the function of the connector. Pin 1 is identified with a square solder pad on the printed circuit board. **Note:** On two pin jumpers, "Closed" means the jumper is on and "Open" means the jumper is off the pins.



Jumper Settings		
Jumper	Jumper Settings	Note
JP29	Open (Jumper off the pins): Default Closed (Jumper on the pins): Reset	MG9072 Chip Reset
JP18	Open (Jumper off the pins): Default Closed (Jumper on the pins): Reset	Buzzer Reset*

\*The buzzer sound indicates that a condition requiring immediate attention has occurred.

**The buzzer alarm is triggered by the following conditions:**

1. Hard drive failure
2. System temperature over 45° Celsius.



## SGPIO and I<sup>2</sup>C Modes and Jumper Settings

This backplane can utilize SGPIO or I<sup>2</sup>C. SGPIO is the default mode and can be used without making changes to your jumpers. The following information describes which jumper must be configured to use SGPIO mode.

SGPIO Settings (Default)		
Jumper	Jumper Setting	Notes
JP33	2-3	Controller ID #1
JP34	1-2	Backplane ID #1 1-2: ID#0 2-3: ID#1
JP36	2-3	Controller ID #2
JP37	2-3	Backplane ID #2 1-2: ID#0 2-3: ID#1
JP38	Open (Jumper off pins)	I <sup>2</sup> C Reset #2
JP40	Open (Jumper off pins)	I <sup>2</sup> C Reset_SDOOUT#1
JP41	Open (Jumper off pins)	I <sup>2</sup> C Reset_SDOOUT#2
JP42	2-3	I <sup>2</sup> C Backplane ID_SDIN#1
JP43	2-3	I <sup>2</sup> C Backplane ID_SDIN#2
JP50	Open (Jumper off pins)	I <sup>2</sup> C Reset #1

Note: For SGPIO settings to work properly, use different backplane IDs for JP34 and JP37. When JP34 is set to 1-2 (ID#0), set JP37 to 2-3 (ID#1). Conversely, when JP34 is set to 2-3 (ID#1) set JP37 to 1-2 (ID#0)

<b>I<sup>2</sup>C Settings</b>		
Jumper	Jumper Setting	Notes
JP33	2-3	Controller ID #1
JP34	1-2	Backplane ID #1 1-2: ID#0 2-3: ID#1
JP36	2-3	Controller ID #2
JP37	2-3	Backplane ID #2 1-2: ID#0 2-3: ID#1
JP38	Closed (Jumper on the pins)	I <sup>2</sup> C Reset #2
JP40	Open (Jumper off the pins)	I <sup>2</sup> C Reset_SDOOUT#1
JP41	Open (Jumper off the pins)	I <sup>2</sup> C Reset_SDOOUT#2
JP42	2-3	I <sup>2</sup> C Backplane ID_SDIN#1
JP43	2-3	I <sup>2</sup> C Backplane ID_SDIN#2
JP50	Closed (Jumper on the pins)	I <sup>2</sup> C Reset #1

## SAS Port Connections in I<sup>2</sup>C and SGPIO Settings

Use the following chart when connecting this backplane. If the SAS ports are connected out of order, it is not easy to identify drives using the LED function.

SAS Port Connections in I <sup>2</sup> C and SGPIO Settings		
Port #	I <sup>2</sup> C	SGPIO
# 0 - 3	I <sup>2</sup> C #1	Sideband #1
# 4 - 7	I <sup>2</sup> C #2	Sideband #2

## Front LED Indicators

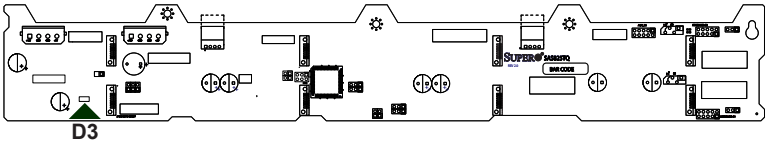

Figure C-4: Front LED

Front Panel LEDs		
LED	State	Specification
D3	On	Overheat/drive failure LED indicator. (Red light: Flashing. Buzzer: On, if activated)

## C-7 Rear Connectors and LED Indicators

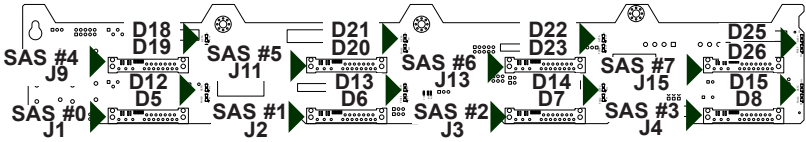

Figure C-5: Rear Connectors and LEDs

Rear SAS/SATA Connectors			
Rear Connector	SAS Drive Number	Rear Connector	SAS Drive Number
SAS #0 J1	SAS/SATA HDD #0	SAS #4 J9	SAS/SATA HDD #4
SAS #1 J2	SAS/SATA HDD #1	SAS #5 J11	SAS/SATA HDD #5
SAS #2 J3	SAS/SATA HDD #2	SAS #6 J13	SAS/SATA HDD #6
SAS #3 J4	SAS/SATA HDD #3	SAS #7 J15	SAS/SATA HDD #7

Rear LED Indicators		
Rear LED	Hard Drive Activity	Failure LED
SAS #0	D12	D5
SAS #1	D13	D6
SAS #2	D14	D7
SAS #3	D15	D8
SAS #4	D18	D19
SAS #5	D21	D20
SAS #6	D22	D23
SAS #7	D25	D26

## Notes

Disclaimer (cont.)

The products sold by Supermicro are not intended for and will not be used in life support systems, medical equipment, nuclear facilities or systems, aircraft, aircraft devices, aircraft/emergency communication devices or other critical systems whose failure to perform be reasonably expected to result in significant injury or loss of life or catastrophic property damage. Accordingly, Supermicro disclaims any and all liability, and should buyer use or sell such products for use in such ultra-hazardous applications, it does so entirely at its own risk. Furthermore, buyer agrees to fully indemnify, defend and hold Supermicro harmless for and against any and all claims, demands, actions, litigation, and proceedings of any kind arising out of or related to such ultra-hazardous use or sale.